

User Guide

Pantum PT16B2B/PT16B3B/
PT12B2A/PT12B3A Series
(BM2300/BM1800 Series)

Monochrome Laser Multifunction Printer

PANTUM

Preface

Welcome to the Pantum series products!

We heartily appreciate your using of Pantum series products!

To protect your vital interests, please carefully read the following statements.

For more information, please visit our official website (www.pantum.com).

Legal Notice

Trademark

Pantum and Pantum logos are registered trademarks of Zhuhai Pantum Electronics Co., Ltd.

Microsoft®, Windows®, Windows Server® and Windows Vista® are trademarks registered by Microsoft Corporation in the United States or other countries/regions.

Apple, AirPrint, Mac, and macOS are trademarks of Apple Inc., registered in the U.S. and other countries. Use of the Works with Apple badge means that an accessory has been designed to work specifically with the technology identified in the badge and has been certified by the developer to meet Apple performance standards.

The Mopria™ word mark and the Mopria™ Logo are registered and/or unregistered trademarks of Mopria Alliance, Inc. in the United States and other countries. Unauthorized use is strictly prohibited.

The Bluetooth® word mark and logos are registered trademarks owned by Bluetooth SIG, Inc. and any use of such marks by Zhuhai Pantum Electronics Co., Ltd. is under license. Other trademarks and trade names are those of their respective owners.

Wi-Fi Direct, Wi-Fi Protected Setup (WPS), WPA, WPA2, WPA3 and Wi-Fi Protected Access are marks of the Wi-Fi Alliance.

The ownership to the names of the software in this User Guide belongs to their respective owned companies in accordance with corresponding license agreement, and they are referred for instructions only.

All other product and brand names herein may be the registered trademarks, trademarks or service marks of their respective owners, and they are referred for instructions only.

Copyright

The copyright of this User Guide is owned by Zhuhai Pantum Electronics Co., Ltd.

It is prohibited to copy, translate, modify and transmit this User Guide by any means or forms without the prior written consent of Zhuhai Pantum Electronics Co., Ltd.

Version:V1.2

Disclaimer

For a better user experience, Zhuhai Pantum Electronics Co., Ltd. reserves the right to make changes to the User Guide. The information contained herein is subject to change without notice. Users are responsible for any damages arising from failing to follow this User Guide. Meanwhile, except the express warranty made in the product maintenance manual or service commitment, Zhuhai Pantum Electronics Co., Ltd. does not make any express or implied warranty or guarantee to this User Guide (including composing or words).

Using this product to copy, print, scan certain documents or images or make other forms of operations may be prohibited by the local laws. If you are uncertain about the legality of using this product for certain documents or images, you should consult your legal advisor in advance.

Safety Precautions

Disconnect the power supply

The product should be placed close to or easily accessible to power sockets, so as to allow easy disconnection of power supply!

Laser Safety

The laser radiation is harmful to the human body. Since laser components are completely sealed in the printer, laser radiation will not leak. To avoid laser radiation, please do not randomly disassemble the printer!

Caution – Use of controls or adjustments or performance of procedures other than those specified herein may result in hazardous radiation exposure.

The printer follows the provisions of Class 1 laser products under CFR standard.



The printer has a Class 3B laser diode, which has no laser radiation leakage among laser components.

The laser components shall comply with the requirements of: U.S. Code of Federal Regulations, 21 CFR 1040, IEC 60825-1

The following label is attached to the laser components inside the printer:



or



Safety Warning

Please note the following safety warnings before using the printer:

Warning



There is a high-voltage electrode inside the printer. Before cleaning the printer, make sure the power is turned off!

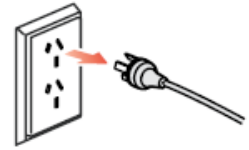

Plugging and unplugging the power cord plug with a wet hand may result in an electric shock.



The fuser unit is hot during and after printing. Touching the fuser unit (the shaded area as shown) may cause burns!

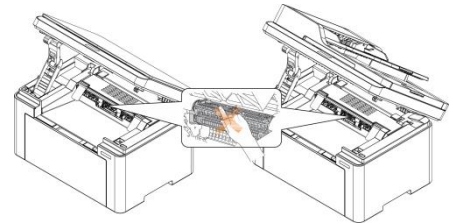

The fuser unit bears a high temperature warning label. Please do not remove or damage this label.

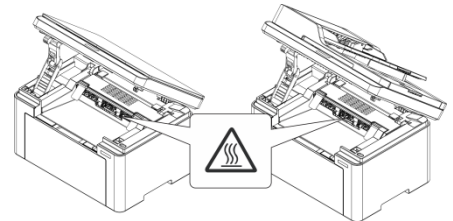

Precautions

Precautions before Using the Printer:

1. Read and understand all instructions;
2. Familiarize yourself with the basic principles associated with operating electrical appliances;
3. Comply with all warnings and instructions marked on the equipment or specified in the manual supplied with the equipment;
4. If the operating instructions conflict with the safety information, please refer back to the safety information, as you may have misunderstood the operating instructions. If you cannot resolve the conflicts, please call the Customer Service Hotline or contact a service representative for help;
5. Before cleaning the equipment, remove the power cord from the AC power supply outlet. Do not use liquid or aerosol cleaners;
6. Please make sure that the equipment is put on a stable desktop surface to avoid serious damage caused by the falling of the equipment;
7. Do not put the equipment near a radiator, an air conditioner, or a ventilation pipe;
8. Do not put any articles on the power cord. Do not put the equipment at the place where its power cord could be stepped on by people;
9. Outlets and extension cords must not be overloaded. This may reduce performance and could result in fire or electric shock;
10. Do not allow pets to chew on the AC power cord or the computer interface cable;
11. Do not allow sharp objects piercing equipment slot, so as to avoid contact with the high-voltage device, which otherwise may result in fire or electric shock. Take care not to spill liquids onto the equipment;
12. Do not disassemble the equipment so as to avoid the risk of electric shock. Necessary repairs may only be carried out by professional maintenance personnel. Opening or removing the cover could result in an electric shock or other potential hazards. Incorrect disassembly and assembly could also result in an electric shock during future use;
13. If any one of the following occurs, disconnect the equipment from the computer and pull out the power cord from the AC wall socket and contact a qualified member of the service personnel for maintenance:
 - Liquid has been spilled into the equipment.
 - The equipment has been exposed to rain or water.
 - The equipment falls, or the cover is damaged.
 - Significant changes in the equipment's performance.
14. Only adjust the control mentioned in the instructions. Incorrect adjustment of other controls may result in damage and mean that professional maintenance personnel need to spend more time fixing it;
15. Do not use the equipment in a thunderstorm so as to avoid the risk of an electric shock. If possible, pull out the AC power cord during a thunderstorm;
16. If you continuously print multiple pages, the surface of the tray will become very hot. Take care not to touch this surface, and keep children away from this surface;
17. The signal wire of the device connected with the printer can not be connected to the outdoors;
18. Please ensure timely ventilation in case of a prolonged use or printing huge amounts of documents in a poorly ventilated room;

19. In standby status, the product will automatically enter into the power saving (sleep) mode if it does not receive any job order for a while (such as 1 minute); and it can realize zero power consumption only if it has not been connected with any external input power supply;
20. As the Class 1 equipment, the product must be connected to the power supply outlet with protective grounding line when using;
21. This product should be placed according to the shipping marks on the product package box during delivery;
22. This product is a kind of low-voltage equipment. When using this product below the specified voltage range, please refer to the product precautions or call Pantum Aftersales Service Centre, if the toner comes off the printed contents, or the equipment starts slowly;
23. This product is sold as a complete machine. The consumers can go to Pantum Aftersales Service Centre to purchase parts they need. If the product sold is inconsistent with the package list, please go to the specified Aftersales Service Centre to solve the problem;
24. Install this product in a place with the temperature between 10°C and 32°C and the relative humidity between 20% and 80%;
25. For security and other reasons the printer may switch to intermittent printing after a certain amount of continuous printing.
26. This device contains licence-exempt transmitter(s)/receiver(s) that comply with Innovation, Science and Economic Development Canada's licence-exempt RSS(s). Operation is subject to the following two conditions:
 - (1) this device may not cause harmful interference, and
 - (2) this device must accept any interference received, including interference that may cause undesired operation.
27. FCC and IC RF Radiation Exposure Statement Caution:

To maintain compliance with the FCC's and IC's RF exposure guidelines, place the product at least 20cm from nearby persons.
28. Warning: Changes or modifications to this unit not expressly approved by the party responsible for compliance could void the user's authority to operate the equipment.
29. The power consumption of the product is 3.137W in networked standby if all wired network ports are connected and all wireless network ports are activated;
30. This Class B digital apparatus complies with Canadian ICES-003.
31. To avoid the danger of fire or electric shock, please only use the power cord provided with this product or authorized replacements approved by the manufacturer.
32. The power cord provided with this product is intended for this product only. Do not use it with other devices as it may cause fire, electric shock, or other injuries.
33. Do not use flammable sprays or combustible solvents near or inside the machine. Additionally, do not place them near or inside the machine as it may cause fire or electric shock.
34. This device is restricted to indoor use when operating in the 5150-5350MHz frequency range to reduce the potential for harmful interference to co-channel mobile satellite systems in all EU/EFTA member states, Turkey and the UK.
35. This transmitter must not be co-located or operating in conjunction with any other antenna or transmitter. This equipment should be installed and operated with a minimum distance of 20 centimeters between the radiator and your body.
36. Please keep this User Guide properly.

Legal Information



This symbol indicates that, at the end of your product's life, it must not be discarded as domestic waste. Instead, you should dispose of your used equipment at a designated collection point for the recycling of waste electrical and electronic equipment. Ref: EU Directive 2002/96/EC on Waste Electrical and Electronic Equipment (WEEE). Please contact your distributor / supplier for further information.



This symbol indicates that the product is applicable to indoor use instead of outdoor use.

European Community (EC) directives conformity

This symbol indicates that the product complies with the protection requirements related to electromagnetic compatibility and safety of electrical device (for use within a specific voltage range) in the approximate and harmonized regulations of members of Directive 2014/30/EU and Directive 2014/35/EU of the European Parliament and of the Council.



Radio Equipment directive 2014/53/EU only for products with wireless function. The manufacturer of this product is: Zhuhai Pantum Electronics Co., Ltd., Building 02, 06 and 08, No.888 Shengping Avenue, Pingsha Town, Zhuhai City, Guangdong Province, 519000 PR China.

A declaration of conformity to the requirements of the Directives is available upon request from the Authorized Representative.

This product satisfies the Class B limits of EN 55032 / EN 55035 and safety requirements of EN 62368-1.

	AT	BE	BG	CH	CY	CZ	DK	DE	EE	EL	ES	FI
	FR	HR	HU	IE	IS	IT	LI	LT	LU	LV	MT	NL
	NO	PL	PT	RO	SE	SI	SK	TR	UK(NI)			
	UK											

Note: only applicable for product with 5GHz Wifi function.

Table of Contents

01 Before Using the Printer	1
Product View.....	1
Control Panel	3
02 Paper and Print Media	5
Paper Specification	5
Loading Paper.....	6
Paper and Manuscript Use Process.....	7
Scanning With Tablet.....	7
Scan with the automatic document feeder (ADF).....	9
03 Driver installation and uninstallation.....	11
Driver Setup.....	11
One-click Installation (For Windows and macOS).....	11
Uninstall Driver.....	12
Method to uninstall driver under Windows	12
Method to uninstall driver under macOS	12
04 Wired network setup (applicable to wired network models).....	13
Set IP Address	13
Automatic Setting.....	13
Manual Setting.....	13
05 Wireless network setup (applicable to Wi-Fi models).....	14
Wireless network setup tools	14
Preliminary preparations.....	14
Setup methods of wireless network setup tools.....	15
How to disable the Wi-Fi network connected.....	15
06 Web server.....	16
Visit the embedded Web server.....	16
07 Print.....	17
Print Function.....	17
Print Settings	18
Setting the printing parameters	18
Duplex Print.....	18
08 Copying.....	19
Copying function	19
Common copying setting.....	19
Multipage.....	20

Collated copy	21
manual duplex copying	21
ID copy settings	23
Receipt setting	23
09 Scan	24
Pull Scan	24
Windows system scan.....	24
macOS System Scan	25
Push Scan	26
Scan to PC.....	26
Scan to E-mail	26
Scan to FTP.....	27
Scan to SMB.....	28
10 Routine Maintenance.....	29
Cleaning the Printer	29
Maintenance of Laser Toner Cartridge	33
About laser toner cartridge	33
Replace Laser Toner Cartridge	34
11 Troubleshooting.....	37
Clearing Jammed Paper	37
Middle jam.....	37
A paper jam occurs on the automatic document feeder (ADF)	39
Software Failure.....	41
Error Message.....	42
Common Troubleshooting	43
Common Problems.....	43
Image Defects.....	45
12 Product Specifications	48
Overview of the Specifications	48
Print Specifications	50
Copy Specifications.....	50
Scan Specifications.....	50

01 Before Using the Printer

Product View

Side view (1)

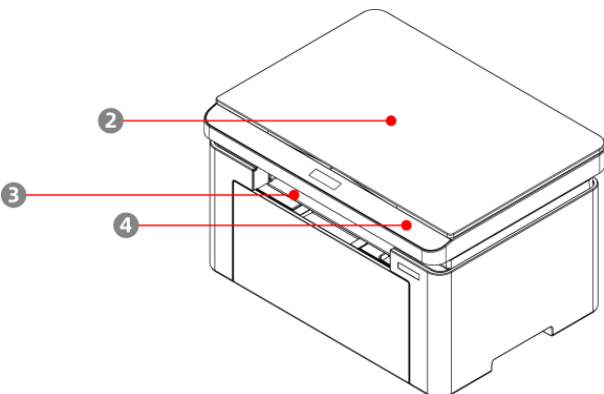
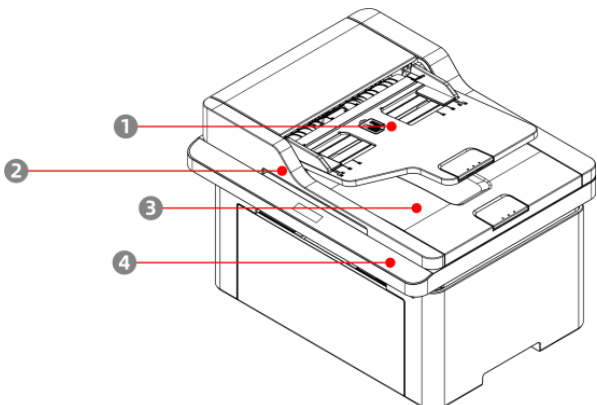
No.	BM2300/BM2300W/BM2300NW/ BM1800/BM1800W Series	BM2300A/BM2300ANW Series
		
1	Cover of automatic document feeder	This is used to remove the paper jammed in scanning for the ADF.
2	Cover of scanner	Open the cover of scanner to place the scanned originals on its glass plate.
3	Output Bin	For storing the printed paper.
4	Control Panel	Indicate printer status to conduct set operation.

Side view (2)

No.	BM2300/BM2300W/BM2300NW/ BM1800/BM1800W Series	BM2300A/BM2300ANW Series
-----	---------------------------------------------------	--------------------------

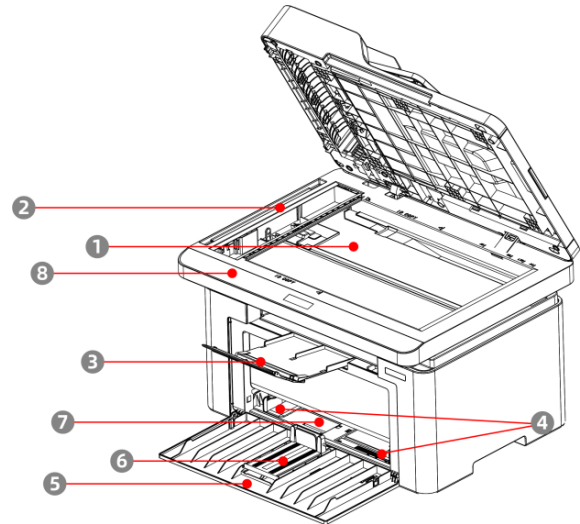
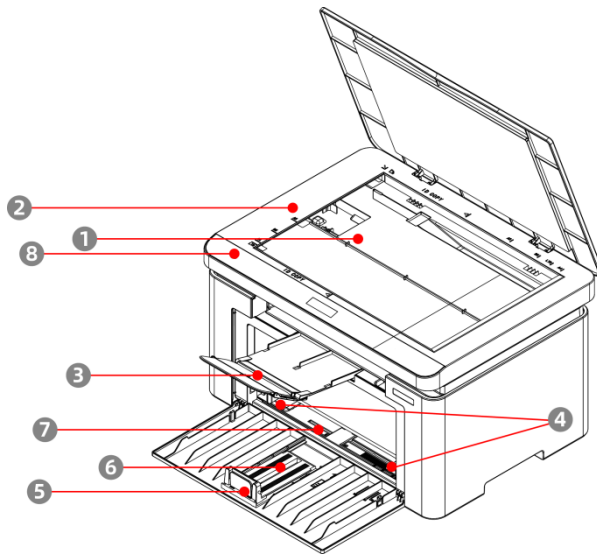

1	Glass Platen	It is used to place the original document scanned from the flatbed.
2	Scanning Platform	It is used to place the original document to be scanned
3	Output Tray	Prevent the printed paper from slipping off.
4	Automatic Feed Paper Deflector	Slide the paper guide to match the width of the paper
5	Paper Stop	Slide the paper stopper to match the length of the paper
6	Feeder Tray	It is used to place the print media.
7	Automatic Feeder Tray	It is used to place the print media.
8	Power switch	It is used to power on/off the printer

Rear View

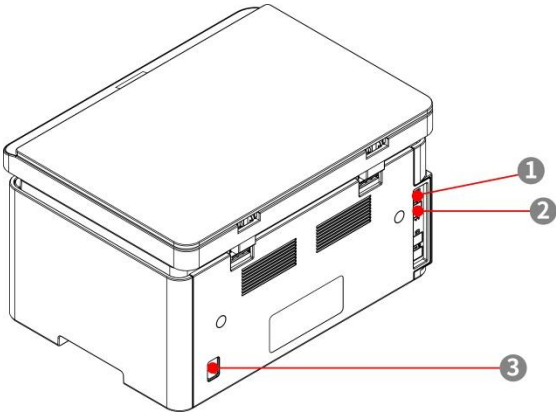
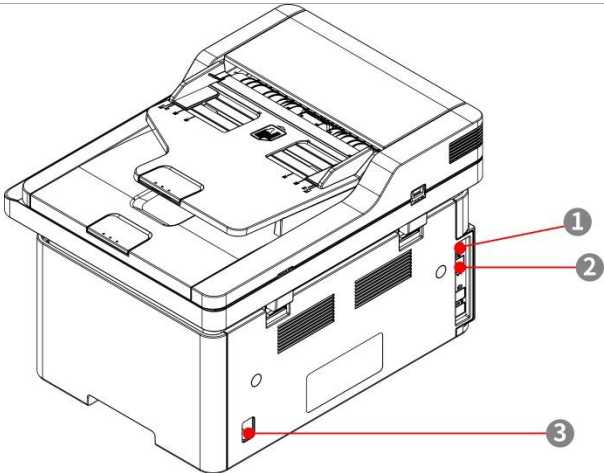
No.	BM2300/BM2300W/BM2300NW/ BM1800/BM1800W Series	BM2300A/BM2300ANW Series
		
1	USB Interface	For connecting product to computer with USB cable.
2	Network Interface	For connecting product to network with network cable.
3	Power Interface	For connecting product to power with power cord.

Control Panel

Control Panel Overview

The layout of the printer control panel is shown below:

Control panel with Wi-Fi function

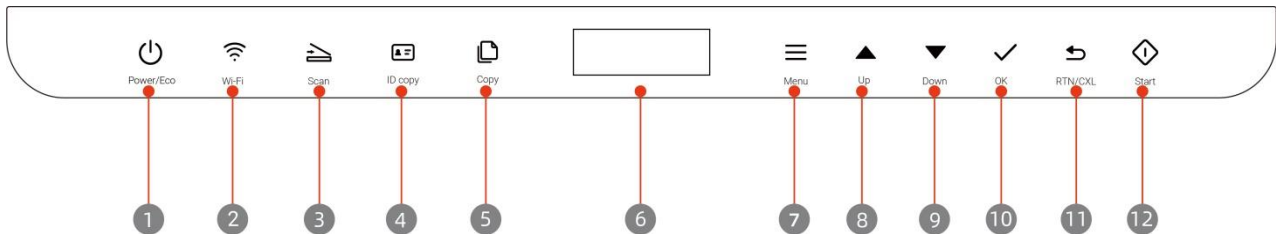

Control panel without Wi-Fi function

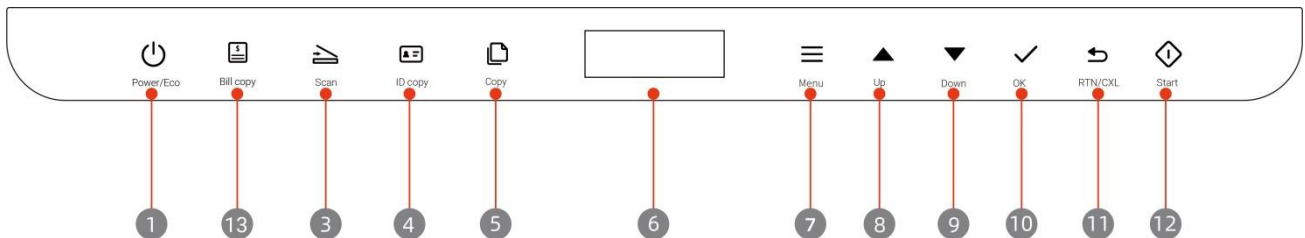

Serial No.	Name	Functions
1	Power/Eco button	Press this button to enter the ECO mode or wake up the printer from the ECO mode.

2	Wi-Fi button	<p>When the WiFi is disconnected: press the WiFi button to enable WiFi hotspot and Bluetooth, and print “wizard page for Wi-Fi connection of mobile equipment” (applicable to Wi-Fi model only).</p> <p>When the WiFi is connected: press the WiFi button to enable Bluetooth search (applicable to Wi-Fi model only).</p> <p>Long press Wi-Fi button: WPS will be enabled if Wi-Fi is disconnected; Wi-Fi will be disconnected if it has already been connected (applicable to Wi-Fi model only).</p>
3	Scan button	Press this button to enter scan mode.
4	ID copy	Press this button to enter ID card copy mode.
5	Copy button	Press this button to enter copy mode.
6	LCD Display	Display the operating interface and product information.
7	Menu button	Press this button to open the main menu of control panel.
8	Up	Scroll up for search
9	Down	Scroll down for search
10	OK button	Confirm the selection on the screen.
11	Back/Cancel button	<p>Press this button to go back to the previous menu.</p> <p>Execute cancel operation.</p> <p>When the copy mode is in idle state interface, restore "Number of Copies" to 01.</p>
12	Start button	<p>Start the corresponding operations after the operation setting is completed.</p> <p>When paper feed failed, press this button to restart the paper pickup for printing.</p>
13	Bill Copy button	Press this button to enter bill copy mode

02 Paper and Print Media

Paper Specification

Automatic Feeder Tray	Media Type	Plain paper, thick paper, transparent film, carton paper, label paper, envelope, thin paper
	Media size	A4,A5,A6,JIS B5,ISO B5,B6,Letter,Legal,Executive,Statement,Monarch envelope,DL envelope,C5 envelope,C6 envelope,NO.10 envelope,Japanese Postcard,Folio,Oficio,Big 16k,32k,16k,Big 32k,ZL,Yougata4,Postcard,Younaga3,Nagagata3,Yougata2, Custom
	Media weight	60~163 g/m ²
	Feeder tray volume	150 pages (80 g/m ²)
	Output tray volume	100 pages (80 g/m ²)

Note: • 80 g/m² standard paper is recommended for this printer.

• This printer supports using the special paper for printing. Special paper includes: label paper, envelope, transparent film, thick paper, carton paper, thin paper.

• When using special media to print, it is recommended to load one piece of paper at one time.

Loading Paper

The steps are as follows:

1. Open the feeder tray.

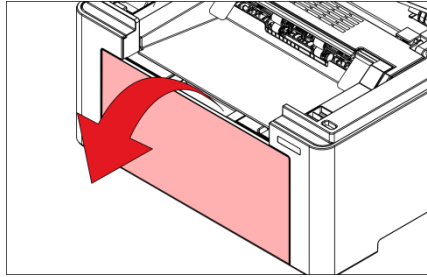

2. Slide the automatic feed guides to match both sides of the paper.

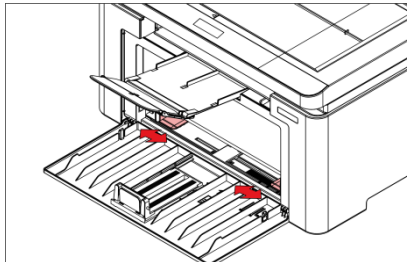

3. Raise the output tray to avoid the paper from slipping and falling.

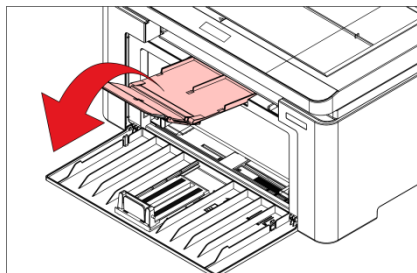

4. Load the paper into the automatic feeder tray with the print-side up.

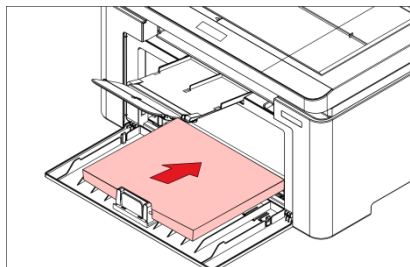

5. Slide paper stopper to match the paper size.

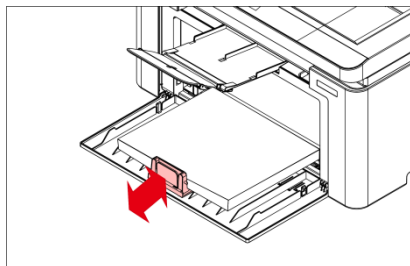

Note: • If the paper loaded into the automatic feeder tray at one time exceeds 150 pages, paper will jam or cannot be fed in.

- When using the printed paper, please make the side to be printed (the blank side) up.
- When printing on A5 paper, it is recommended that the paper is fed in landscape orientation, which can extend the service life of the laser toner cartridge.



Warning



After printing, please immediately remove the paper, envelopes and transparencies. Stacking paper or envelopes may cause a paper jam or the paper curling.

Paper and Manuscript Use Process

Manuscript requirements:

Source	Type	Size
Automatic document feeder (ADF)	Plain paper	A4,A5,B5,A6,Letter,Folio,Legal
Platen	Plain paper, thick paper, transparent film, carton paper, label paper, envelope, thin paper	A4,A5,B5,Letter,Full Platen, Custom

Scanning With Tablet

Note: • Printer appearance may differ because of various models and functions, so the schematic diagram is only for your reference.

Operation steps:

1. Lift up the scanner cover.

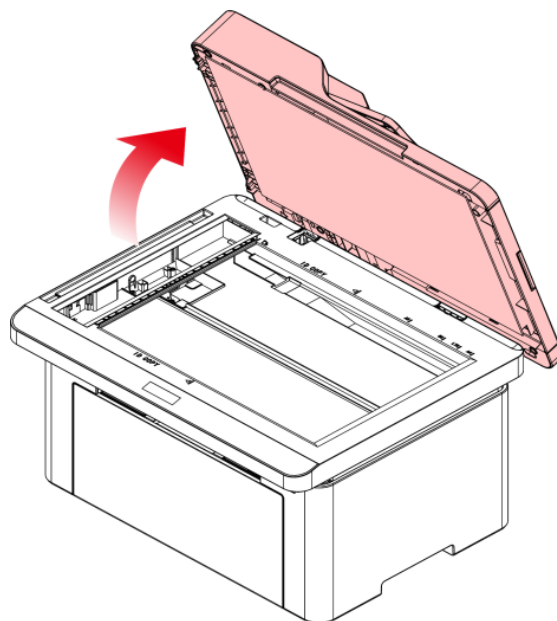

2. Load the manuscript face down.

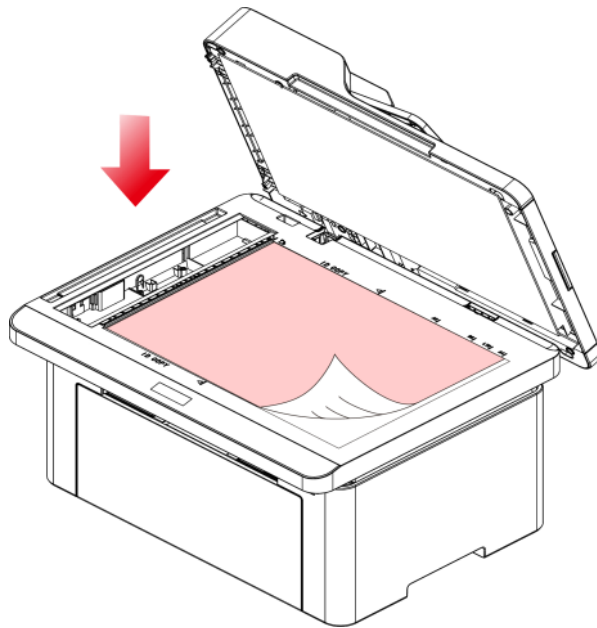

3. Align the manuscript to match the appropriate paper size.

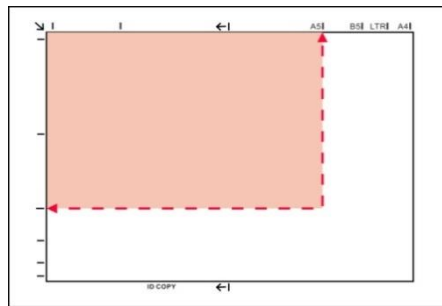

- Note:** • If the manuscript does not match with any size marker, please align the upper-left corner of the manuscript with the arrow.
- Make sure there is no document in the ADF. If a document is detected in the ADF, it will be more preferential than that on glass platen.

4. Close the scanner cover gently.

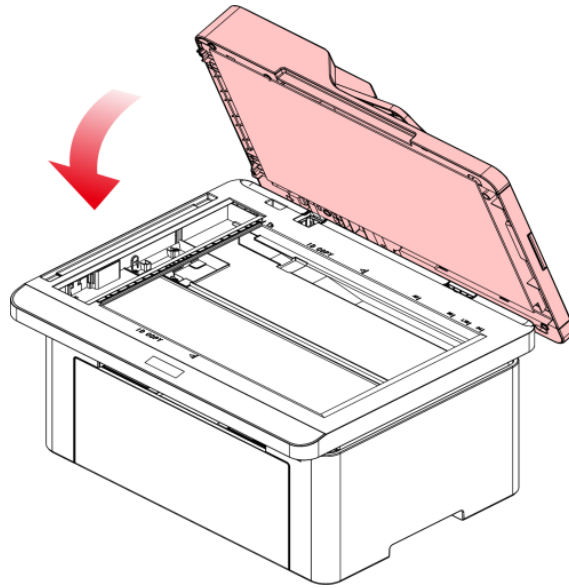

- Note:**
- Please put the paper or document on the scanner glass after the glue, ink or correction fluid are completely dried.
 - Rough textured, uneven, oil stained and extremely smooth paper will make printing effect poor.
 - Please make sure that there is no dust, fluff, etc. on the paper.
 - Paper shall be put on a flat surface and stored under a cool and dry environment.
 - To avoid influencing the definition, please don't open the scanner cover during scanning with the platen.

Scan with the automatic document feeder (ADF)

1. Put the original into the ADF with its front upward and top fed first.

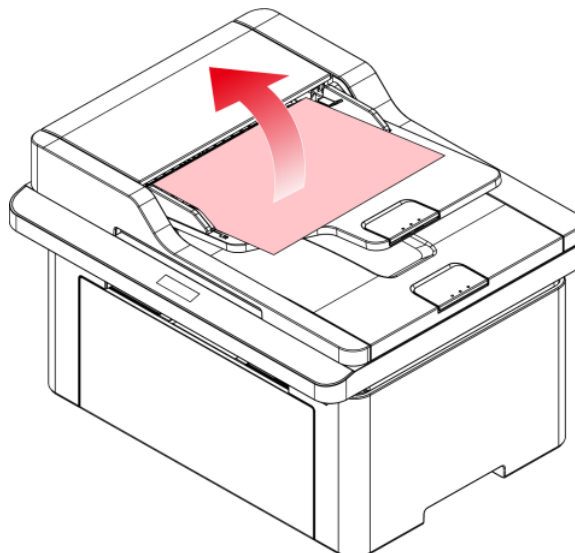

2. Adjust the document guide till it gets close to the paper stack.

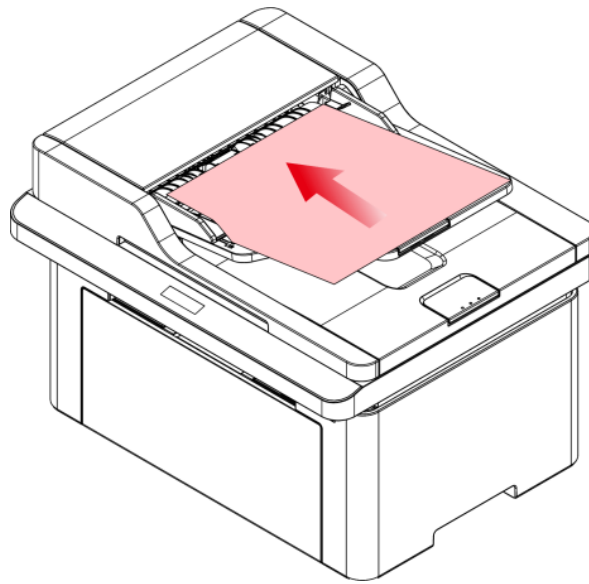

Note: • ADF/Document Feeder can hold up to 35 sheets of paper and feeds them sheet by sheet.

03 Driver installation and uninstallation

Driver Setup

This software provides a one-click installation method for driver installation on Windows and macOS systems, which can help you automatically complete the driver installation faster and more easily.

Note: • Driver installation interface may differ because of different models and functions, so the schematic diagram is only for your reference.

One-click Installation (For Windows and macOS)

One-click installation provides you with three installation methods: "Wi-Fi", "USB", and "Wired Network". This manual focuses on the "Printer Installation by USB Connection".

Connect printer via USB cable

1. Connect the printer to computer via USB cable, then power the printer on.
2. Insert the accompanying installation disk into the computer CD drive, or log in to Pantum official website (www.pantum.com) to download the drive.

Note: • Some computers may be unable to auto play the CD because of system configuration. Please double click "Computer" icon, find "DVD RW driver", then double click "DVD RW driver" to run the installation procedure.

3. Read and agree to the terms contained in the End User License Agreement and the Privacy Policy, click the "Next" button in the lower right corner of the interface to enter the driver installation interface.
4. For Windows, follow Step 5. For macOS, enter PC password before proceeding to Step 5.

5. The setup will start when you click on "One-click installation" under USB. The setup may take a while, depending on your PC configuration. Please wait.

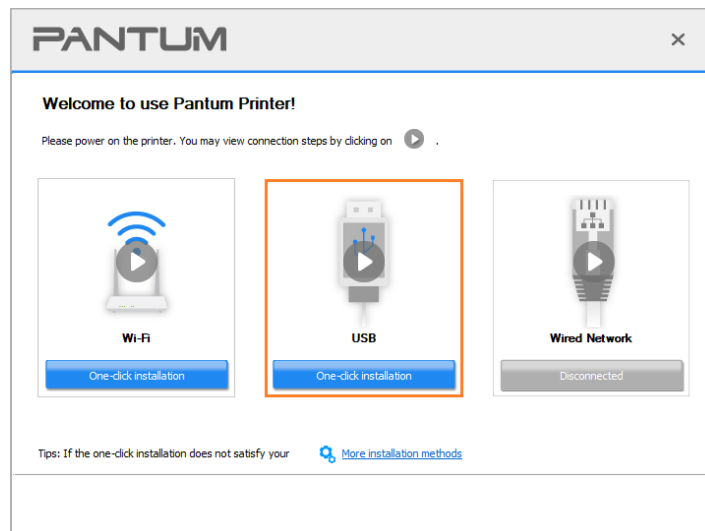

6. After the installation, click "Print & Test Page" button. If your printer prints the test page successfully, it means that you have installed the driver correctly.

Uninstall Driver

Method to uninstall driver under Windows

Windows 7 is taken as the example in the following operation. The information on your computer screen may differ because of multiple operating systems.

1. Click the Start menu of computer and then click All programs.
2. Click Pantum, and then Click Pantum XXX Series.
Pantum XXX Series where XXX represents product model.
3. Click uninstall to delete the driver according to instructions on uninstall window.
4. Restart computer after finishing unloading.

Method to uninstall driver under macOS

macOS10.14 is taken as the example in the following operation. The information on your computer screen may differ because of multiple operating systems.

1. Click "Go" - "Applications" - "Pantum" - "Utilities" - "Pantum Un-install Tool".
2. Delete the driver as instructed in the pop-up Uninstall window.
3. Uninstall complete.

04 Wired network setup (applicable to wired network models)

In case printers support wired network printing, they can be connected to network to control printer to print in wired network mode.

Set IP Address

The IP address of the printer may be automatically obtained through DHCP function or set manually.

Automatic Setting

DHCP automatic setting function is enabled by default on the printer.

1. Connect the printer to the network through a network cable and complete the startup preparation work.
2. The printer will receive the IP address assigned by server automatically. It may take server minutes to receive IP address under the influence of network environment.

You can print the "Network Configuration page" to view the printer's IP address. If the IP address is not listed, please check the network environment or wait a few minutes and try again.

Note: • If DHCP server fails to assign IP address automatically, the printer will get the link-local address assigned by printer automatically: 169.254.xxx.xxx.

Manual Setting

To set up IP address for printer through the control panel of printer manually.

To set up IP address for printer through the embedded Web server manually.

05 Wireless network setup (applicable to Wi-Fi models)

Based on the model, the printer model with Wi-Fi print function supports two types of wireless network connection: Wi-Fi Station and Wi-Fi Direct. Usually, only one connection is enabled between the computer and the printer at a time.

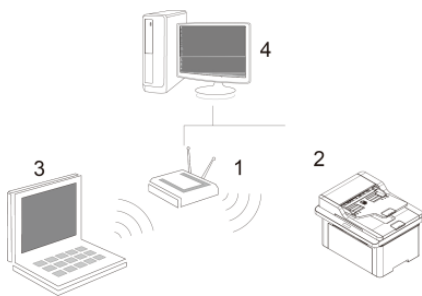

Wi-Fi Station: connecting to a wireless device via router

1. Access point (wireless router)
2. Wireless network printer
3. Computer connecting to access point via wireless network
4. Computer connecting to access point via network cable

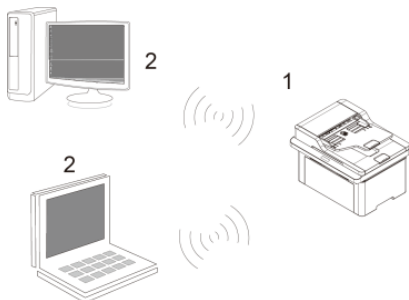

Wi-Fi Hotspot

The wireless computer is directly connected with the wireless device.

Wireless network setup tools

If your computer has been installed with a driver and had been connected to wireless network, but the wireless network was changed, you can set it again with wireless network setup tools.

Preliminary preparations

1. Access point (wireless router).
2. A computer that has been connected to network.
3. A printer that has wireless network function.

Setup methods of wireless network setup tools

Take the wireless network setup tool in computer.

1) **Windows system:** Click the "Start menu" – "All programs" - "Pantum" — Product name – "Wireless network setup tool".

2) **macOS system:** click "Go" - "Applications" - "Pantum" - "Utilities" - "Wireless Network Configuration Tool" on the computer Finder menu bar.

How to disable the Wi-Fi network connected

Connect the wireless network in infrastructure mode by the steps above. If connected, the Wi-Fi light on the control panel is normally on. Press and hold this button for more than 2s to disconnect from Wi-Fi network (Wi-Fi light will be off).

06 Web server

You can manage printer setup via the embedded Web server. You can manage printer setup via the embedded Web server.

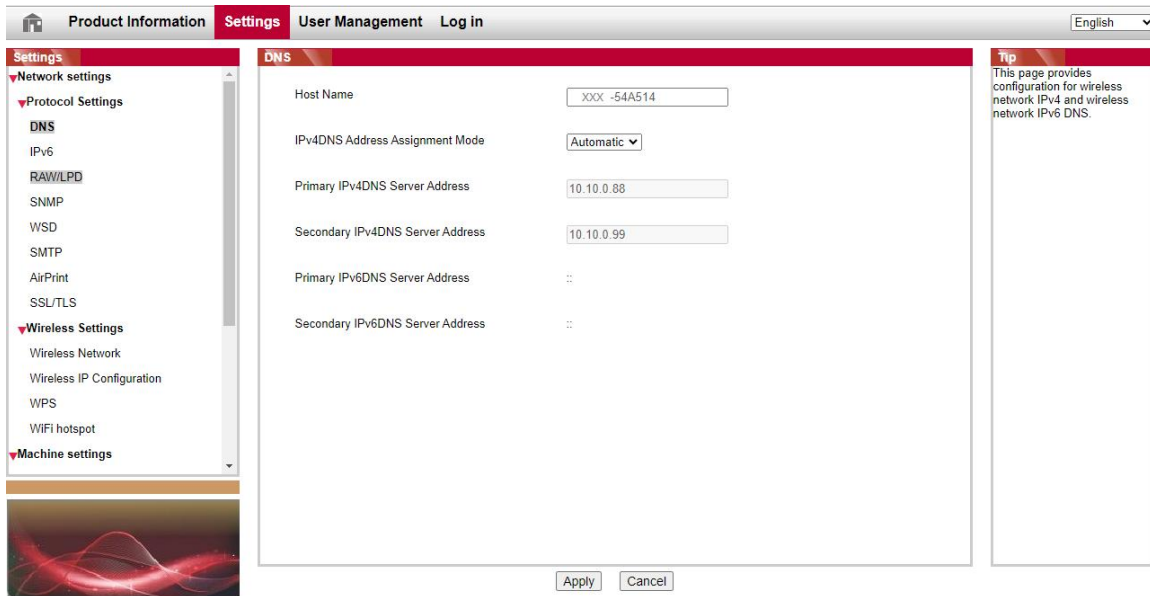

Visit the embedded Web server





1. Turn on the power of printer and computer.
2. Connect the printer to network to ensure that the printer is connected to the network where the computer is connected to.
3. Input the IP address of printer in the address bar of Web browser to visit the Web server imbedded in printer.
4. Click "Log in" option, input user name and password (the default user name is admin and the initial password is 000000) and click "Log in".

Note: • For safety reasons, you are suggested to change the default password, which can be finished in the "User Management" interface.

07 Print

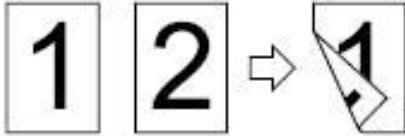
Print Function

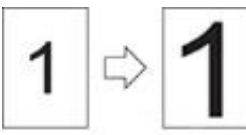
You can set the print function through "Start"->"Devices and Printers"- select corresponding printer right click – set print function in "Printing preferences". Some functions are as follows:

Functions	Diagram
Manual Duplex	
Collate	
Reverse Print	
N-in-1	
Poster Print (for Windows system only)	
Zoom Print	
Booklet printing	
Custom Size	

- Note:** • You can select the 2 x 2 Poster Print in N-in-1 to enable the poster printing function.
- You can open the Printing Preferences and click Help button to view the specific function explanation.

Print Settings

Setting the printing parameters

You can set up printing parameters with the following two methods before sending printing work.

Operating system	Temporary printing setup change	Permanent default setup change
Windows 7	1. Click "File" menu – "Print" – "Select printer" - "Printer properties" (the detailed steps may differ because of multiple operating systems).	1. Click "Start" menu- "Control Panel" – "Devices and Printers". 2. Right click on the printer icon, select "Printing preference" and then change setup and save it.
macOS	1. Click "File" menu – "Print". 2. Change setup in the window popping out.	1. Click "File" menu – "Print". 2. Change setup in the window popping out and click to save the preset. (Select preset every time before printing, or print according to default setup.)

- Note:** • Priority of App setup is senior to printer setup.

Duplex Print

Ensure that certain amount of paper is loaded into the automatic feeder tray before printing.

- Note:** • If the paper is thin, it may wrinkle.
- If the paper is curled, make it flat and put it back into the manual feeder tray.
 - If paper jams occur when Manual Duplex is enabled, please refer to the [printer cleaning instructions](#).
 - "Do not attempt Manual Duplex when the Paper Type is set to "Thick Paper" or "Transparent Film".
 - If more than 150 sheets of paper are loaded into the Auto Feed Tray, it may cause paper jams or paper pick-up failure.

How to perform Manual Duplex

1. Open the print job to be printed.
2. Select Print from the File menu.
3. Select printer of the corresponding model
4. Click "Printer Properties" to configure the print setting.
5. Select "Duplex Print" under the "Basics" tab, and choose either "Long Edge" or "Short Edge" option.
6. Click "OK" to complete the print setting. Click "Print" to enable Manual Duplex.

08 Copying

Copying function

Copying function	Instructions	
Common copying	Multipage	Print a multi-page document to a piece of paper.
	Clone	Print several identical images to a piece of paper.
	Poster	Print a one-page original to pieces of paper.
	Collated copy	Collate copies of an original.
	Manual dual-side	It supports manual duplex copying for originals.
	Image quality	Set the definition mode to improve the copying effect.
	Intensity	Adjust deep-light copying effect by setting intensity.
	Resizing	Reduce or enlarge the size of image copied.
	Paper setting	Set the paper size and type.
ID copy	Arrangement mode	Set the Layout for Copying ID Card
	Intensity	Adjust deep-light copying effect by setting intensity.
	Paper Size	Set the paper size.
Receipt copying	Intensity	Adjust deep-light copying effect by setting intensity.
	Paper Size	Set the paper size.

Note: • The collate and manual duplex copy are only supported by ADF models.

Common copying setting

Change relevant setting with “copying setting menu” for better copying effect.

1. Press "Copy" and then "Menu" on control panel to enter the "Menu Setting" interface.
2. Press "OK" to enter the "Copy Setting" interface.
3. Press “direction key to select option to be set and press “OK key” to set option.

Note: • Once the settings options for image quality, brightness and contrast, zoom, and paper size are selected, the settings will remain in effect.

• For multipage, clone, poster, collated copy and manual dual-side setting, set recovery mode as default setting after completing copying, switching panel key or restarting machine.

• After “multipage” and “clone function” are set, “paper dimension” supports “A4” and “Letter” only.

Multipage

With setting on all-in-one feature, a 2- or 4-page document could be copied to one piece of paper. Copying with the ADF and the glass platen are both supported.

The multipage includes 3 modes:

(1) Two-in-one:

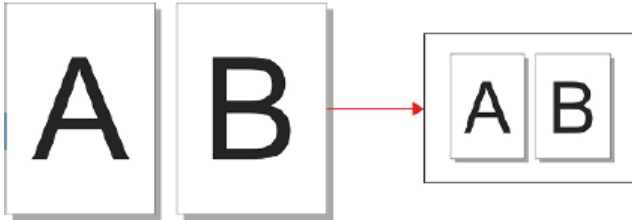

(2) Horizontal four-in-one:



(3) vertical four-in-one:



Note: • "Multipage" and "resizing function" cannot be set at the same time.

Collated copy

The "Collated Copies" feature supports only copying with the automatic document feeder (ADF). The collated copy includes 2 modes:

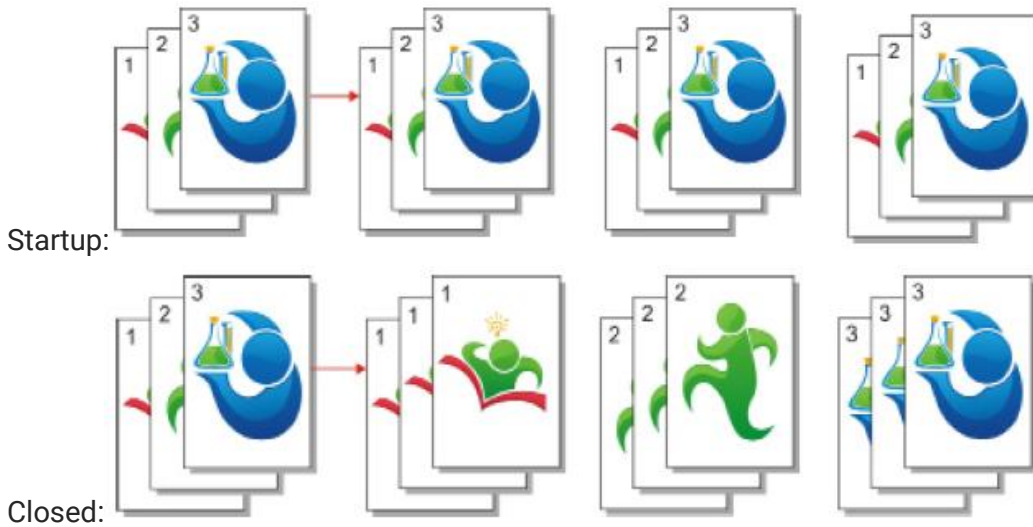

manual duplex copying

In case of manual duplex copying of original, choose ADF mode.

Steps to use Manual Duplex Original Copying

1. Put an original into the ADF with its front upward and its top fed first; meanwhile, make sure there are some paper in the carton.

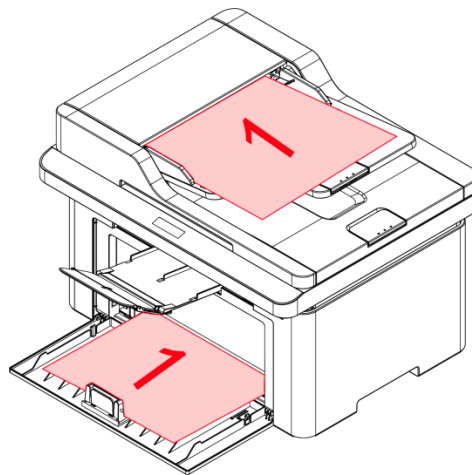

2. Operate in accordance with the procedure of ordinary copy; choose the "manual duplex copy" mode and press "OK" to save the settings.

3. Click "Copy" button to copy.

4. Paper exited should be with the direction as shown in the figure:

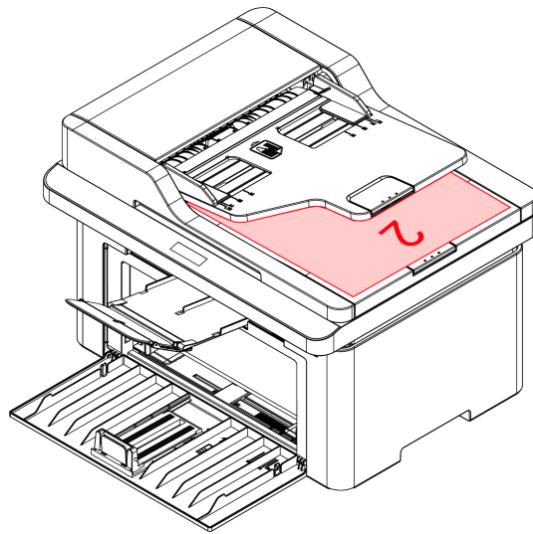

5. After completion of copying one side, put the paper into the entrance as shown in figure (without turnover or rotation).

Note: • If the turnover prompt on panel times out, the machine will execute one-sided copying automatically.

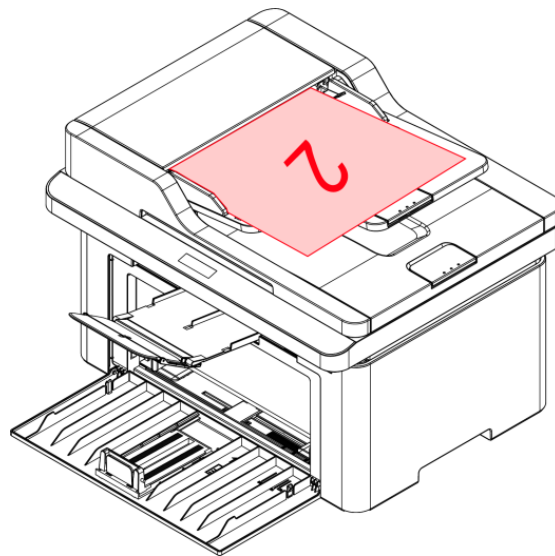

6. Press "Start" to begin copying the other side.

ID copy settings

For better copying effects, you can change the corresponding settings via the "ID Copy Settings" menu.

1. Press "ID Copy" and "Menu" on the control panel to enter the "Menu Settings" interface.
2. Press "OK" button and enter "ID Printing Settings" interface.
3. Press "direction key to select option to be set and press "OK key" to set option.

Receipt setting

For better copying effect of bills, you can enter the "Bill Copy Setting" menu to change relevant settings.

1. Press "Bill Copy" and then "Menu" on control panel to enter the "Menu Settings" interface.
2. Press "OK" to enter the "Bill Copy Setting" interface.
3. Press "direction key to select option to be set and press "OK key" to set option.

09 Scan

This printer provides two types of scan: "Push Scan", which means scanning through the printer's Control Panel operations; "Pull Scan" which means scanning through PC terminal scanning the application. Before scanning, please be sure a printer driver has been installed in the computer. This product complies with the TWAIN and Windows Image Application (WIA) standard. If using the application which supports TWAIN and WIA standard, users can use the scan function and directly scan the images to the open application.

Pull Scan

You can scan from the PC scan application via USB, wired, or wireless connection. Make sure the printer is properly connected before scanning.

Windows system scan

Pantum Scan Application

Operation Steps:

1. Double click on "Pantum Scan Application" on the computer.
2. The prompt window is shown as below:

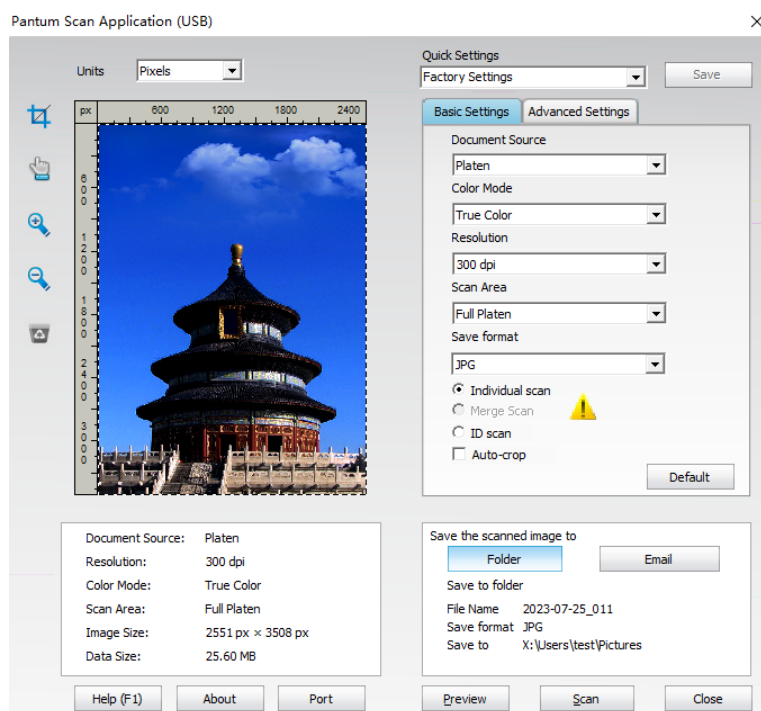

3. Set Scan in the right list. Click "Scan" on the bottom right corner and start scan.

macOS System Scan

ICA Scan

Open ICA via "Print and Scan"

Operation Steps:

1. After installing the printer driver, click "System Preferences" icon on the bottom left corner of the computer desktop.
2. After the window pops up, click on "Print and Scan".
3. After the pop-up window appears, select the desired printer and click the "Scan" button.
4. Click on "Open Scanner" and the scan window will pop up.
5. Click on "Show Details" on the bottom right corner to set the scan parameters.
6. Click on "Scan" on the bottom right corner and start scan.

Call CIA through applications

Operation Steps:

1. Click on "Finder" icon on the bottom left corner of the computer desktop, Find "Image Capture" in "Applications", and click to launch the application.
2. After the window pops up, set the scan information in the right list of "Basic Setting" and "Advanced Setting". Click on "Scan" and start scan.

TWAIN Scan

Take Photoshop as an example. (CS2 and earlier versions are supported)

Operation Steps:

1. Launch Photoshop, click on "File" – "Import" on the top left corner and select TWAIN Scan.
2. After the window pops up, set the scan information in the right list of "Basic Setting" and "Advanced Setting". Click on "Scan" and start scan.

Push Scan

This section is mainly to introduce how to scan files to PC, E-mail and FTP with the printer's control panel.

Note: • For a single page scanned to PC/E-mail/FTP, you can save it as PDF, TIFF, JPEG or OFD.
• If you choose to scan to PC with N-UP Scan under the ADF scanning mode, the scanned documents will be PDFs by default; For those scanned to E-mail/FTP with N-UP Scan, you can save them as PDF, TIFF, JPEG or OFD.

Scan to PC

You may operate the printer's control panel to scan a file to PC. (Only support connection method of USB connection line.)

1. Be sure the printer and the computer are both switched on and connected with each other properly.
2. Put an original on the glass platen or into the ADF.
3. Press "Scan" button on the control panel, and press "▲" or "▼" to select "Single Page Scan" or "Merge Scan", then press "OK" button.
4. Press "Menu" and then "OK" to enter the "Scan Setting" interface.
5. Press "▲" or "▼" to select the options under "Scan to", and then press "OK".
6. Select scanning parameters according to your needs, then press "Start" to start scanning.
7. If you want to perform a merge scan, place the documents that you want to continue scanning on the glass platen, press the "Start" button and proceed with scanning the second page. (ADFsd can make scan continuously without interruption.)

Scan to E-mail

You can scan the file as an attachment into the email application. The steps are as follows:

1. Be sure the printer and the computer are both switched on and connected with each other properly.
2. Set up SMTP client.
3. Configure the E-mail address book.
4. Put an original on the glass platen or into the ADF.
5. Press "Scan" button on the control panel, and press "▲" or "▼" to select "Single Page Scan" or "Merge Scan", then press "OK" button.
6. Press "Menu" and then "OK" to enter the "Scan Setting" interface.
7. Press "▲" or "▼" to select the options under "Scan to", and then press "OK".
8. Press "▲" or "▼" to select "Scan to E-mail" and press "OK" button.
9. Press "▲" or "▼" to select "E-mail Address Book" or "Group Mail" and press "OK" button.
10. Press "▲" or "▼" to select the address or group. Press "OK" button. Press "Start" to start the scan.

11. If you want to perform a merge scan, place the documents that you want to continue scanning on the glass platen, press the "Start" button and proceed with scanning the second page. (ADFsd can make scan continuously without interruption.)

Instructions for settings of group e-mail sending:

Set the group name for group e-mail sending by webpage, and set the members, i.e.the receivers, in the group of group email. After finishing scanning, firmware will send the scanned documents to the mail server. Then mail server sends the documents to every member of the group.

Scan to FTP

Be sure the user is in an Internet-connected environment in scanning files to FTP server. If you want to scan large files, you may need to input the server address, user name and password to log in the server, with specific operation steps as below:

1. Be sure the printer and the computer are both switched on and connected with each other properly.

2. Configure the FTP address book.

3. Put an original on the glass platen or into the ADF

4. Press "Scan" button on the control panel, and press "▲" or "▼" to select "Single Page Scan" or "Merge Scan", then press "OK" button.

5. Press "▲" or "▼" to select "E-mail Address Book" or "Group Mail" and press "OK" button.

6. Press "▲" or "▼" to select the options under "Scan to", and then press "OK".

7. Press "▲" or "▼" to select "Scan to FTP", and then press "OK".

8. Press "▲" or "▼" to select the server. Press "OK". Press "Start" to start the scan.

9. If you want to perform a merge scan, place the documents that you want to continue scanning on the glass platen, press the "Start" button and proceed with scanning the second page. (ADFsd can make scan continuously without interruption.)

Scan to SMB

To use “Scan to SMB” function, you need to create a shared folder on the Windows or Mac computer first.

Create a shared folder

Windows 7 is taken as example for description of the following steps.

1. Right click the folder under Windows system you want to share, and select Properties.
2. Select the “Share” tab, and click “Share”.
3. In the pop-up “Network Access” window, click the drop-down menu, select “Everyone”, and click “Add”.
4. Change the “Everyone” permission level added in Step (3) to “Read/Write”, and click “Share (H)” in the lower right corner.
5. If your shared folder path is displayed at the network path, it means it is successfully shared.

“Scan to SMB” configuration

1. Be sure the printer and the computer are both switched on and connected with each other properly.
2. To configure SMB address book (It can be configured via Web server.)
3. Put an original on the glass platen or into the ADF
4. Click “Scan - Scan to SMB” on printer control panel.
5. Select proper scan setting, click “Scan” button to make a scan.

10 Routine Maintenance

Note: • Printer appearance may differ because of different models and functions, so the schematic diagram is only for your reference.

Cleaning the Printer

Note: • Please use mild detergents.

Please clean the printer in accordance with the following steps:

1. Turn off the main power switch and unplug the power cord, USB cable, phone cord and the network cable.

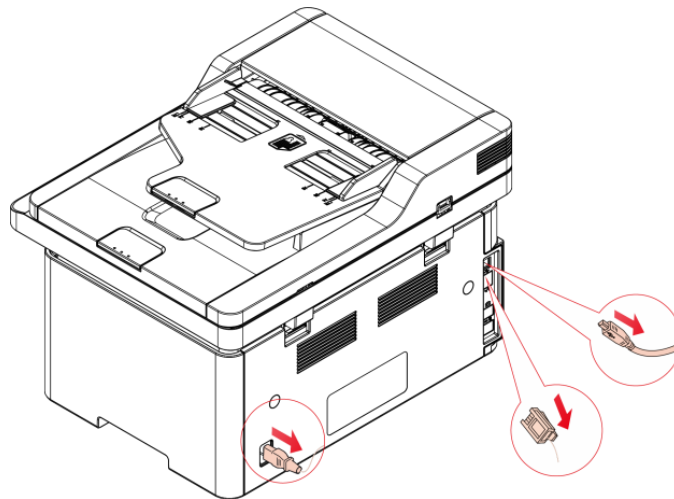

2. Use a soft cloth to wipe the outside of the printer clean.

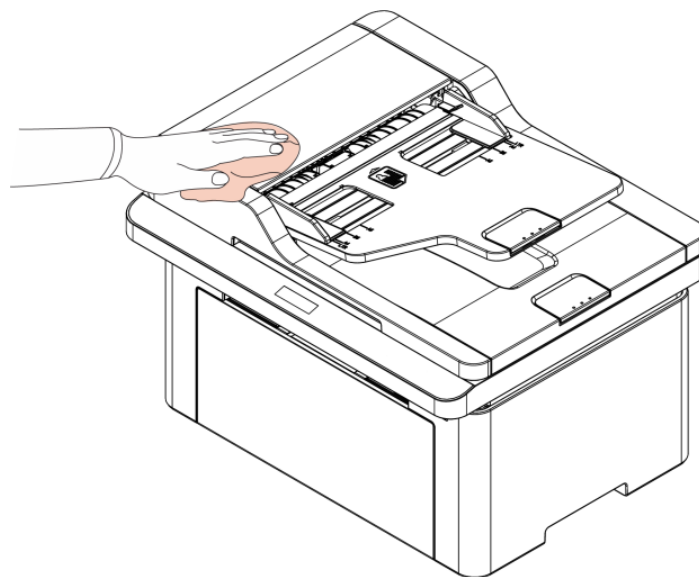

3. Raise the cover and gently wipe the platen glass with a soft cloth.

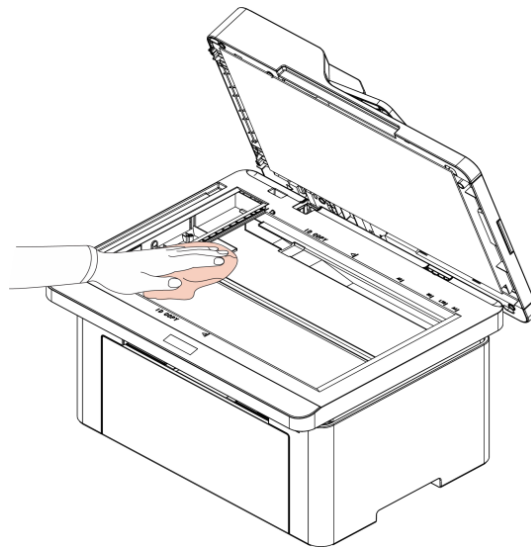

4. Raise the scanning platform until it is locked.

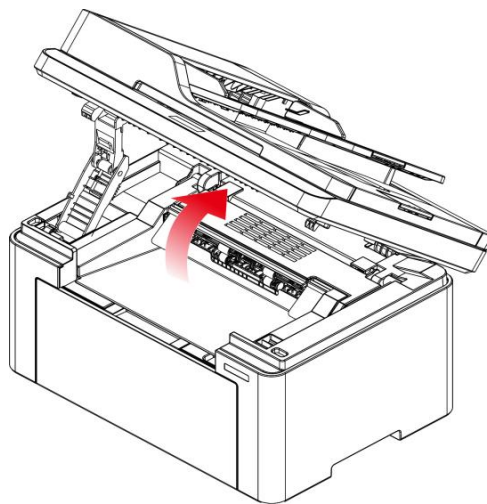

5. Open the output bin by the upper right ridge of the concave section.

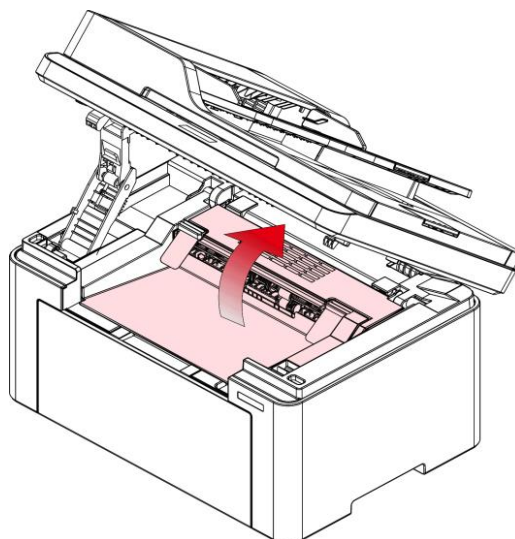

6. Remove the laser toner cartridge along the guides.

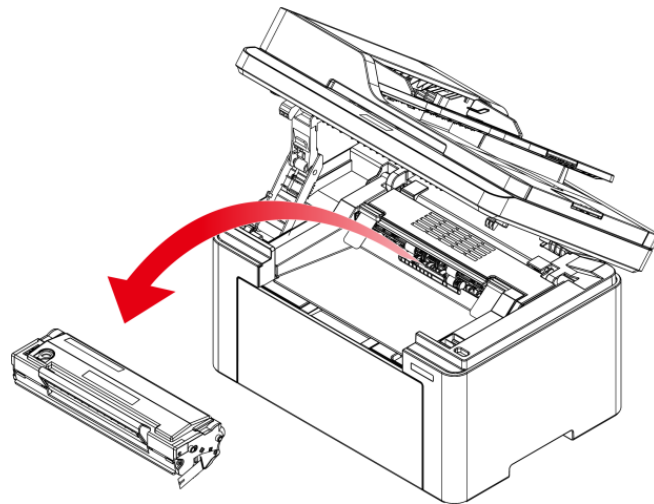

Note: • When removing the laser toner cartridge, put the cartridge in a protective bag or wrap it with thick paper to avoid direct light damaging the photosensitive drum.

Warning

Some parts of the printer are still hot within a short time after use. When opening the front cover or rear cover to clean the parts inside the printer, please do not touch the parts in the shaded area as shown in the following picture, so as to avoid burns.

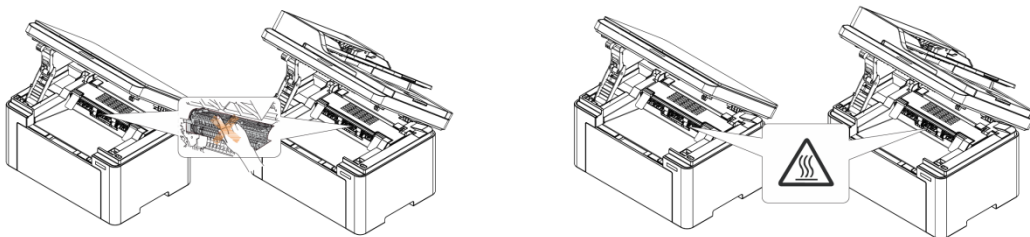

7. Gently wipe the dustproof mirror of laser scanning surface with a cotton swab or a dry and lint-free soft cloth with a little alcohol.

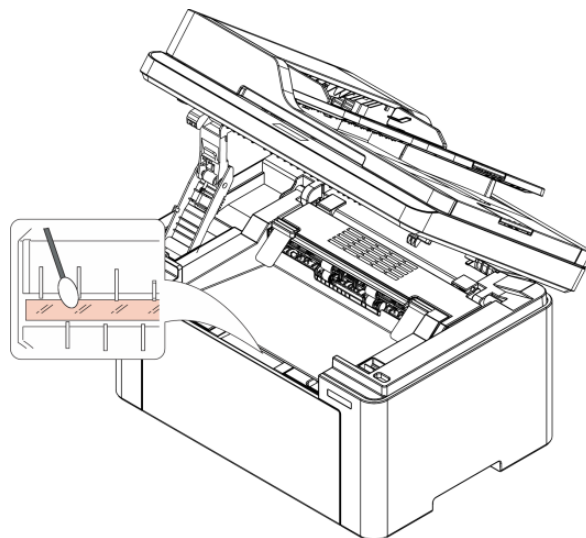

8. Clean the inside of the printer by using a dry and lint-free cloth to gently wipe the shaded area as shown in the picture below.

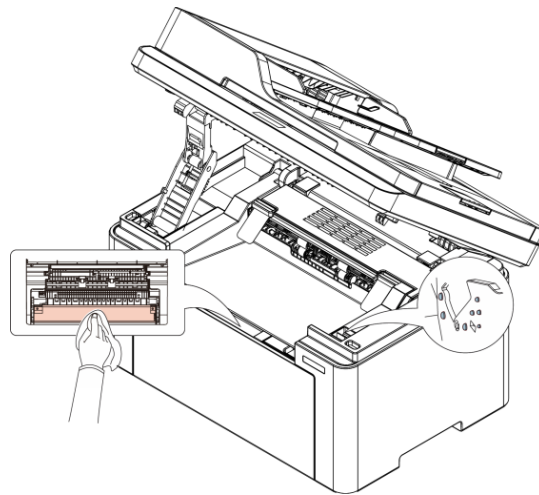

Note: • For ADF machine, you need to regularly clear scraps. Please use a soft cloth to wipe the location shown in the figure.

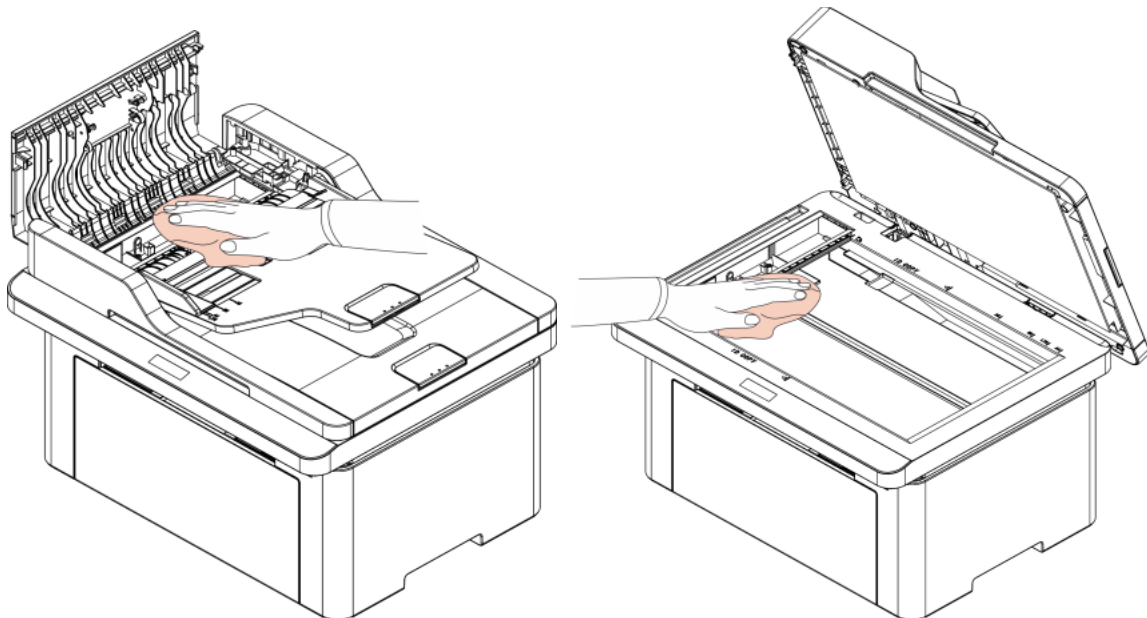

Maintenance of Laser Toner Cartridge

About laser toner cartridge

1. Use and Maintenance of Laser Toner Cartridge

For better print quality, please use the original Pantum laser toner cartridge.

- Please store the laser toner cartridge in a dry dark place.
- Do not attempt to refill the laser toner cartridge without authorization. Otherwise, the resulting damage is not included in the printer warranty.
- Please store the laser toner cartridge under a cool and dry environment.
- Toner inside the laser toner cartridge is combustible. Please do not put the laser toner cartridge near any source of ignition, so as to avoid causing a fire.
- When removing or disassembling the laser toner cartridge, please pay attention to the toner leakage problem. In case of the toner leakage resulting in that the toner contacts with your skin or splashes into your eyes and mouth, please immediately wash with clear water, and consult a doctor immediately if you feel unwell.
- When placing the laser toner cartridge, please keep it away from the area reachable by children.

2. Service Life of Laser Toner Cartridge

- Service life of the laser toner cartridge depends on the amount of toner that print jobs require.
- "Laser toner cartridge end of life" displayed on the LCD screen means the laser toner cartridge has reached its service life. Please replace the laser toner cartridge.

Replace Laser Toner Cartridge

Note: • before replacing the laser toner cartridge, please pay attention to the following:

- The laser toner cartridge surface may contain toner. Please remove it carefully to avoid spilling.
- Put the removed laser toner cartridge on a piece of paper to avoid the toner from accidentally spilling.
- After removing the protective cover, please immediately install the laser toner cartridge into the printer, so as to avoid photosensitive drum damage caused by exposing to too much direct sunlight or indoor light.
- While installing the laser toner cartridge, do not touch the surface of the photosensitive drum so as not to scratch it.

The steps to replace the laser toner cartridge are as follows:

1. Turn off the printer and raise the scanning platform until it is locked.

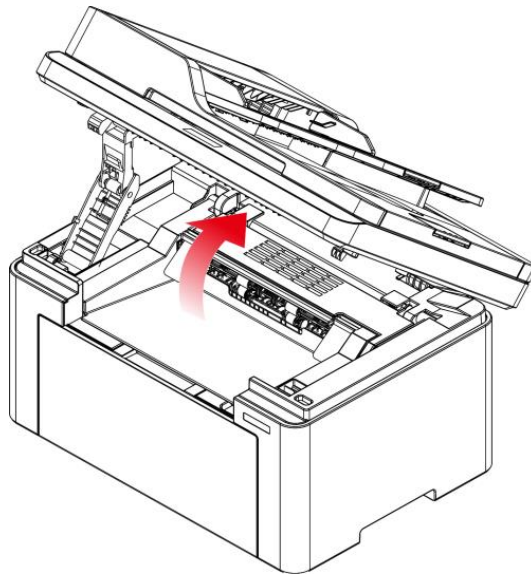

2. Open the output bin by the upper right ridge of the concave section.

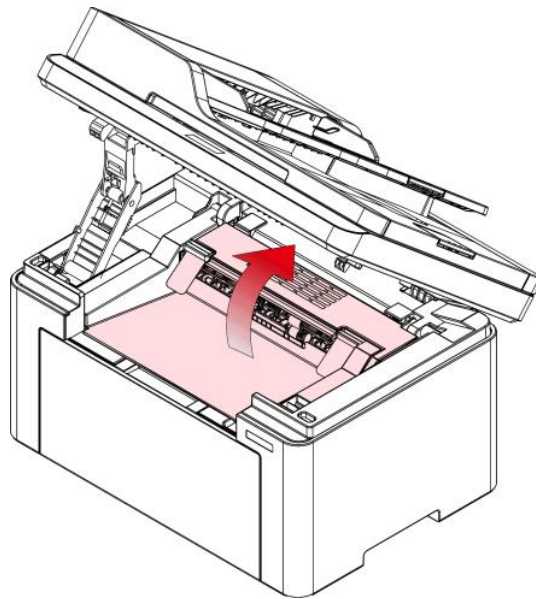

3. Remove the exhausted cartridge along the guides.

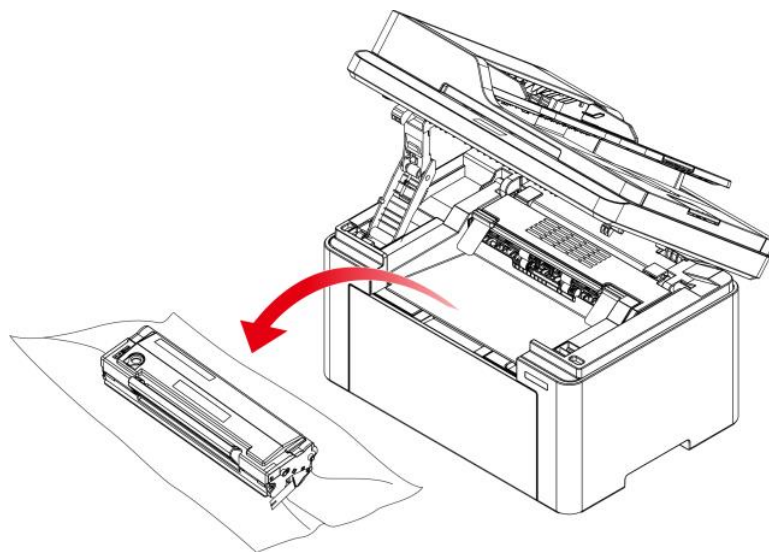

4. Open the package of a new laser toner cartridge, hold the handle of the cartridge and gently shake around 5 to 6 times, so as to make the toner evenly distributed inside the cartridge.

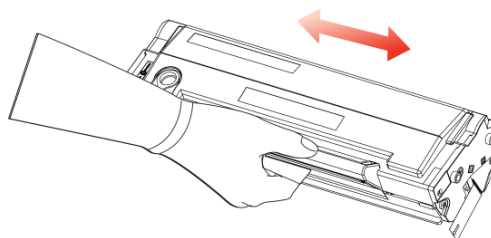

5. Remove the protective cover (vacuum-formed cover) from the laser toner cartridge. Insert the laser toner cartridge along the guide rail into the printer. Press it down in the direction of the arrow until you hear a "click" sound to complete the installation.

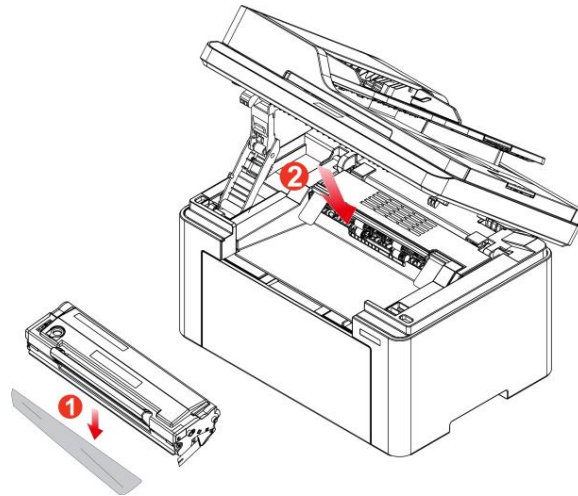

Note: Check whether there is any seal on it before installing the laser toner cartridge into the printer; if there is any, please tear off the seal and then install the cartridge.

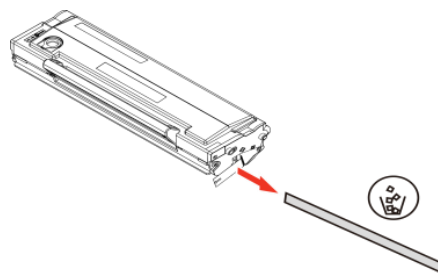

6. Cover the output bin and close the scanning platform.

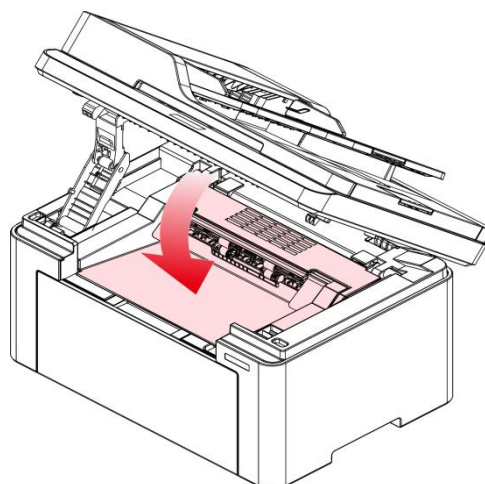

7. Restart the printer, and use the control panel to print an information page.

11 Troubleshooting

Please read this section carefully. It can help you solve common trouble in the printing process. If the problems appeared cannot be solved, please contact Pantum Aftersales Service Center.

Clearing Jammed Paper

Middle jam

Please follow the following steps to clear the jammed paper if you are prompted of a paper jam by the LCD.

1. Raise the scanning platform until it is locked.

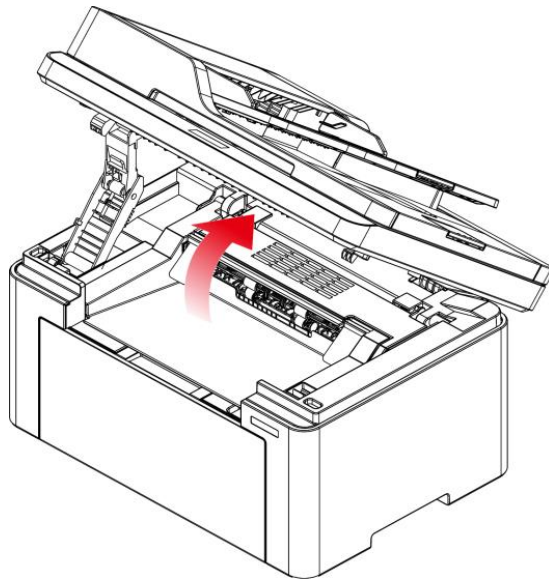

2. Open the output bin by the upper right ridge of the concave section.

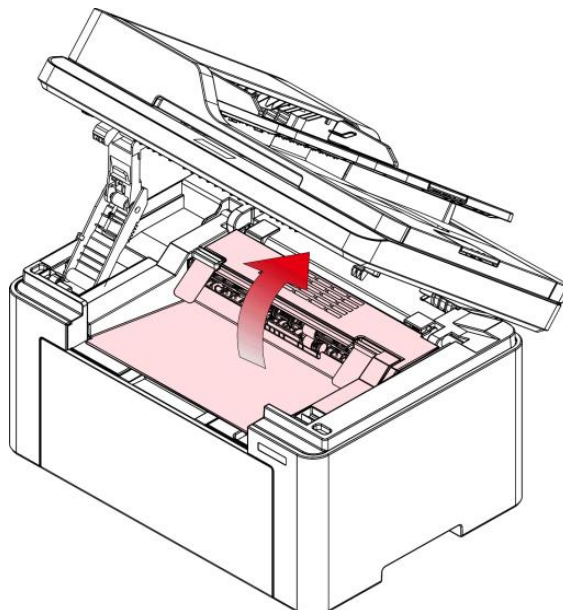

3. Remove the laser toner cartridge along the guides.

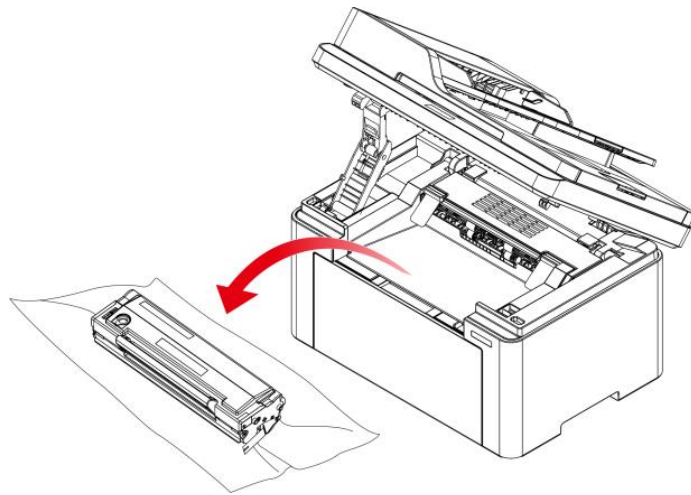

4. Gently draw the jammed paper out along the paper output direction.

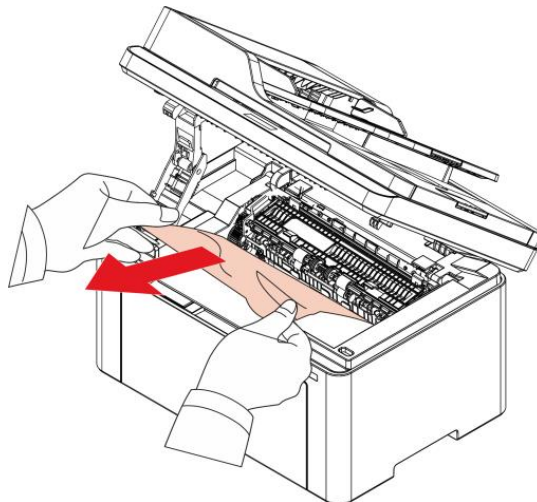

5. After removing the jammed paper, insert the laser toner cartridge into the printer along the guides until you hear a "click" assuring you that the cartridge is fully inserted.

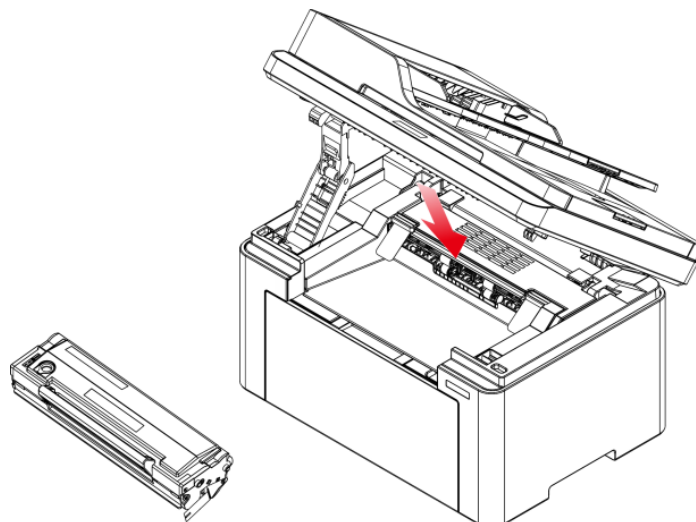

6. Neatly put the paper in the tray, and do not carry out the next print until the indicator light resumes print-ready status.

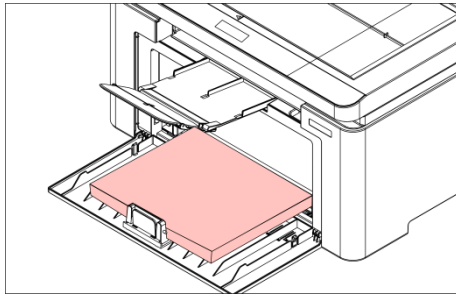

A paper jam occurs on the automatic document feeder (ADF)

1. Open the ADF's top cover.

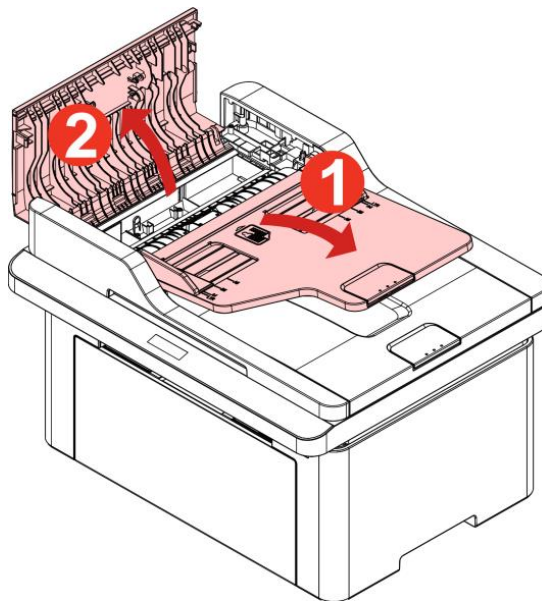

2. Remove the paper jammed from the ADF.

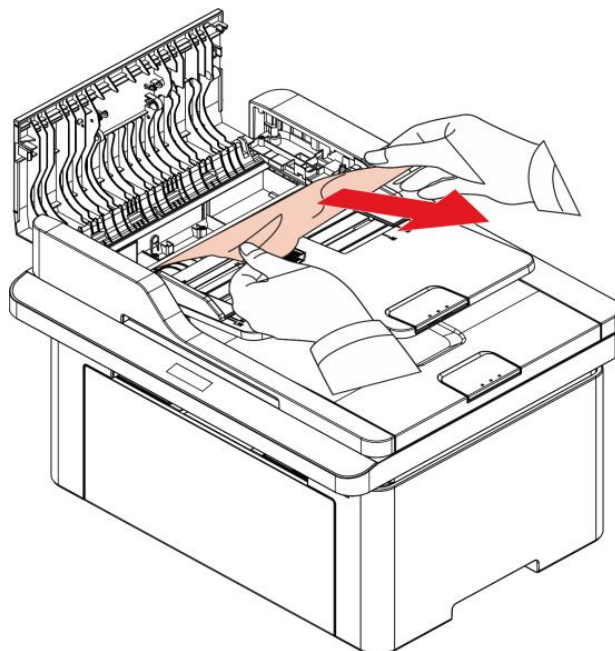

3. After removing the paper jammed, close the top cover and then the printer will be back to the ready state.

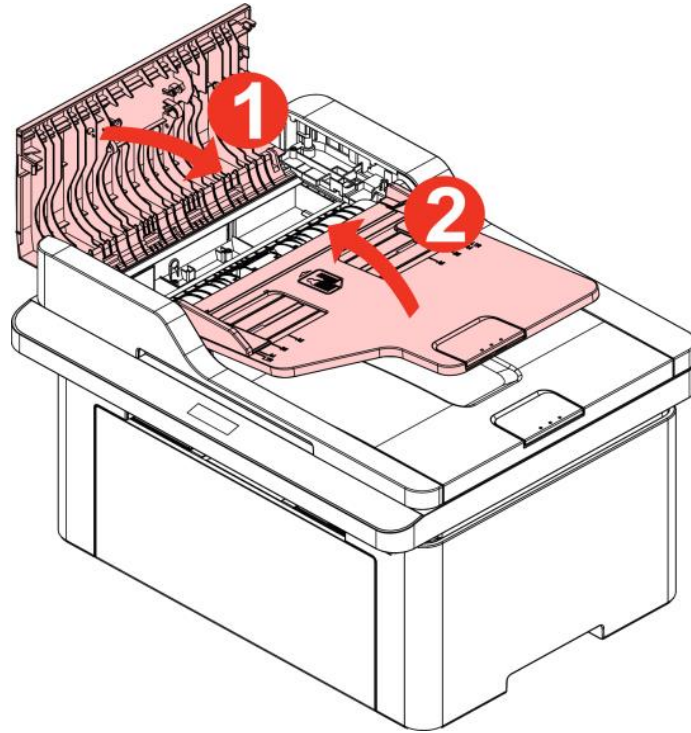

If it is difficult to remove the paper jammed, please try to open the scanner cover and remove it from the pressing block.

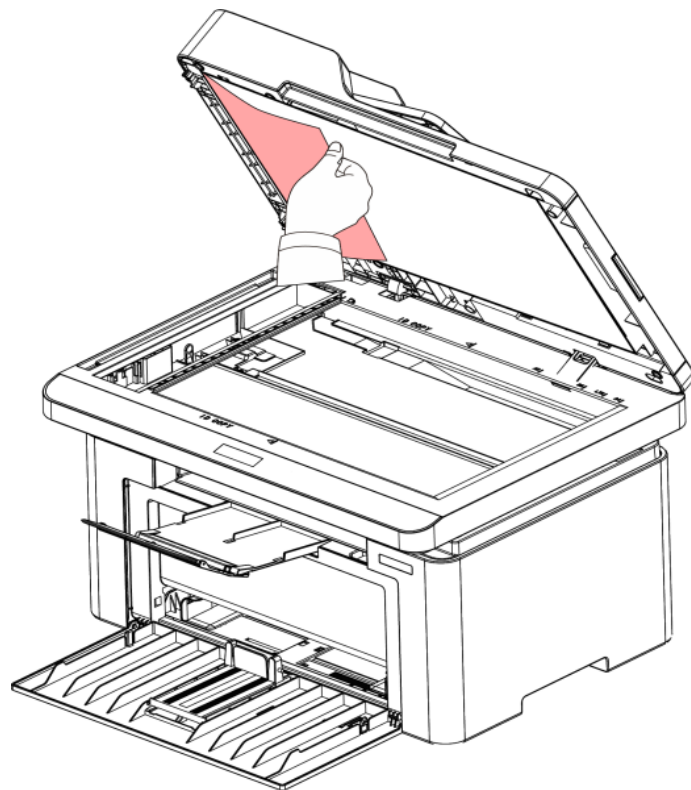

Software Failure

Problem	Solution
The printer icon does not appear in the "Devices and Printers" folder.	Reinstall the printer driver. Ensure that the USB interface cable and the power cord are properly connected.
The printer is in Ready mode but it will not perform any print job.	If the failure still exists after restarting the printer, please reinstall the printer driver. Make sure the network cable of USB cable is connected correctly.
Failed to install the driver	Check whether the print spooler service is enabled. Check the power supply and the connection of the printer.
The driver cannot be used if the IP address of the printer has been changed	Modify the port IP address of the printer driver. If the above method does not work, please reinstall the printer driver. It is recommended that a fixed IP address should be set to the network printer. In the DHCP network, it is recommended to bind the IP address with the MAC address of the printer.

Error Message

Error Message	Cause	Measure
Close Output Bin	The paper bin is not fully closed.	Close Output Bin.
No Laser Toner Cartridge Detected	The laser toner cartridge is installed incorrectly or laser toner cartridge is damaged.	The laser toner cartridge is installed correctly or new laser toner cartridge is replaced.
Toner Low	Cartridge toner is low	Replace New Laser Toner Cartridge
Toner life end	Toner has been used up.	Replace the toner cartridge.
Feed Failure	Paper is not installed correctly. Paper is beyond the specification.	Please install the paper correctly.
Paper jam in printer	Paper is not installed correctly.	Please install the paper correctly.
Scanner is Busy	With other scan jobs.	Please cancel the current scan job or wait for the completion of other scan jobs.
Scan failed	Scanner internal failure.	Please contact Pantum Customer Service.
No paper in ADF	If you have selected ADF as the scan source, this message appears when you start a copy or scan job without loading paper in the ADF.	Please put in the original properly.
Paper jam occurred on ADF	This prompt appears when there is a feed jam or feed failure in copying or scanning with the ADF.	Please remove the paper jam, arrange well and put originals into the ADF for scanning again.

Note: • If the problem persists, please contact the customer service center. See the Three Guarantees certificate for contact details.

Common Troubleshooting



Common Problems

Type of fault	Problem	Cause	Solution
Printing problems	Poor print quality	See details in Image Defects .	See details in Image Defects .
Problems in copying	Failed to copy	<ul style="list-style-type: none"> The scanner is damaged. 	Please contact the customer service center.
	Copy Image Abnormal	<ul style="list-style-type: none"> The scanner is dirty or defective. The toner cartridge is dirty or damaged. 	<ul style="list-style-type: none"> Clean the scanner. It is suggested to replace the original toner cartridge.
Problems with the Printer	The printer does not work	<ul style="list-style-type: none"> Device power is not properly connected. The cable between the computer and the printer is not connected properly. Error in specifying the print port. The printer is offline and User Guide of Printer is checked. The printer has not recovered from an internal error, such as a paper jam, paper empty, etc. Driver program of printer is not installed correctly. The LCD screen prompts error messages. 	<ul style="list-style-type: none"> Ensure proper connection of the power cord. Disconnect and then reconnect the printer cable. Check the Windows printer settings to ensure that the print job has been sent to the correct port. If the computer has more than one port, make sure that the printer is connected to the correct port. Make sure that the printer is in the normal online status. Please eliminate errors so that the printer can recover to its normal state. Unload and reinstall the driver program of printer.
	Online printing does not work	<ul style="list-style-type: none"> The cable between the computer and the printer is not connected properly. The LCD screen prompts error messages. Printer internal failure. 	<ul style="list-style-type: none"> Disconnect and then reconnect the printer cable. Unload and reinstall the driver program of printer.
Problems in scanning	Scanning error	<ul style="list-style-type: none"> Data cable of the device is not properly connected. The scan driver is installed incorrectly. The LCD screen prompts error messages. 	<ul style="list-style-type: none"> Ensure proper connection of the data cable. Reinstall the scan driver.

	Paper feed failure	<ul style="list-style-type: none"> • The print media has been loaded incorrectly. • The print media is out of the supported media range. • The feed roller is dirty. • Too many papers in paper tray. 	<ul style="list-style-type: none"> • Please install the printing medium correctly. If a special printing medium is used, enable the multipurpose feed tray mode. • Please use the print media within the specification range. • Clean the feed roller. • Take the excessive papers out from tray. For printing on a special medium, use the multipurpose feed tray.
Problems with Paper Handling	Paper Jam	<ul style="list-style-type: none"> • Too many papers in paper tray. • The print media is out of the supported media range. • There is foreign matter in the paper path. • The feed roller is dirty. • Internal parts failure. 	<ul style="list-style-type: none"> • Take the excessive papers out from tray. For printing on a special medium, use the multipurpose feed tray. • Make sure to use the paper that meets specifications. For printing on a special medium, use the multipurpose feed tray. • Clean the paper path. • Clean the feed roller.
	Print multipage feed	<ul style="list-style-type: none"> • Excessive static electricity on the print media. • The print media is damp and is sticking together. • Internal parts failure. 	<ul style="list-style-type: none"> • Separate the print media to eliminate some static electricity. It is suggested that you use the recommended print media. • Separate the print media or use better quality and dry print media.

Note: • If the problem persists, please contact the customer service center. See the Three Guarantees certificate for contact details.

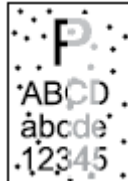
Image Defects

Problem	Cause	Solution
	<ul style="list-style-type: none"> • The print media does not meet usage specification, such as the media is damp or too rough. • The resolution in the print program is set too low, concentration setting is too low, or toner saving mode is ticked. • Toner is low. • The laser toner cartridge is damaged. 	<ul style="list-style-type: none"> • Please properly use the print media within the specification range. • Set the print resolution, concentration, or cancel ticked toner saving mode in the program. • Please use the original laser toner cartridge.
	<ul style="list-style-type: none"> • The laser toner cartridge is dirty or leaks toner. • The laser toner cartridge is damaged. • The print media that does not meet usage specification is used. For example, the media is damp or too rough. • The feed channel is dirty. • If toner spots appear when copying and scanning, the platen glass may be dirty. • The scanner is dirty or damaged. 	<ul style="list-style-type: none"> • Please use the original laser toner cartridge. • Please use the print media within the specification range. • Clean the feed channel. • Clean the platen glass.
	<ul style="list-style-type: none"> • The print media that does not meet usage specification is used. For example, the media is damp or too rough. • The feed channel is dirty. • The internal part of the laser toner cartridge is damaged. • LSU lens inside the printer are dirty. 	<ul style="list-style-type: none"> • Please use the print media within the specification range. • Clean the feed channel. • Please use the original laser toner cartridge. • Clean the LSU lens.
	<ul style="list-style-type: none"> • The print media that does not meet usage specification is used. For example, the media is damp or too rough. • The set paper media for printing is inconsistent with the loaded paper media. • The inside of the printer is dirty. • The laser toner cartridge is damaged. • The internal part of the printer is damaged. 	<ul style="list-style-type: none"> • Please use the print media within the specification range. • Please use the corresponding paper media for printing • Clean the inside of the printer. • Please use the original laser toner cartridge.

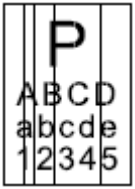

Black vertical stripes

- The laser toner cartridge is dirty.
- The internal part of the laser toner cartridge is damaged.
- The reflective glass of the laser inside the printer is dirty.
- The feed channel is dirty.
- If black vertical stripes appear when copying or scanning, the scanner or the platen glass may be dirty.
- Scanner Light bulb has smudges.
- The scanner is damaged.
- Clean or replace with a new laser toner cartridge.
- Clean the reflective glass of the laser at the back of the printer.
- Clean the feed channel at the back of the printer.
- Clean the scanner or the platen glass.

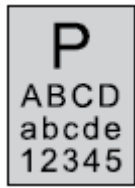

Black background (gray background)

- The print media that does not meet usage specification is used. For example, the media is damp or too rough.
- The laser toner cartridge is dirty.
- The internal part of the laser toner cartridge is damaged.
- The feed channel is dirty.
- The transfer voltage inside the printer is abnormal.
- Scanning exposure.
- If black background or gray background appears when copying and scanning, the platen glass may be dirty.
- Please use the print media within the specification range.
- Clean the feed channel inside the printer.
- Please close the cover on the manuscript, and then carry out copying and scanning.
- Clean the platen glass.

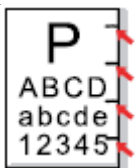

Cyclical traces appear

- The laser toner cartridge is dirty.
- The internal part of the laser toner cartridge is damaged.
- The fuser component is damaged.
- Clean the laser toner cartridge or replace it with a new one.
- Please contact Pantum Customer Service to repair and replace the fuser component.



Skewed pages

- The print media is loaded incorrectly.
- The feed channel of the printer is dirty.
- Ensure correct loading the print media.
- Clean the feed channel inside the printer.

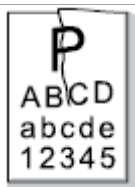

Wrinkled paper

- The print media is loaded incorrectly.
- The print media does not meet the usage specification.
- The feed channel of the printer is dirty.
- The fuser component is damaged.

- Ensure correct loading the print media.
- Please use the print media within the specification range for printing.
- Clean the feed channel inside the printer.
- Please contact Pantum Customer Service to repair and replace the fuser component.



The back of the printout is dirty

- The laser toner cartridge is dirty.
- The transfer roller inside the printer is dirty.
- The transfer voltage inside the printer is abnormal.

- Clean the laser toner cartridge or replace it with a new one.
- Clean the internal transfer components of the printer.



Whole page dark

- The laser toner cartridge is installed incorrectly.
- The internal part of the laser toner cartridge is damaged.
- Abnormal charge inside the printer; the laser toner cartridge is not charged.
- If all-black image appear when copying and scanning, maybe it is scanning exposure, and the cover on the manuscript is not properly closed.
- The scanner is damaged.

- Ensure to install the cartridge correctly.
- Please use the original laser toner cartridge.
- Please first close the cover on the manuscript, and then carry out copying and scanning.

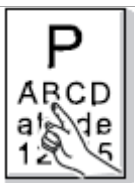

The toner does not adhere to the paper

- The print media that does not meet usage specification, such as the media is damp or too rough.
- The inside of the printer is dirty.
- The laser toner cartridge is damaged.
- The internal part of the printer is damaged.

- Please use the print media within the specification range.
- Clean the inside of the printer.
- Please use the original laser toner cartridge.

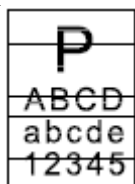

Horizontal stripes

- The laser toner cartridge is incorrectly installed.
- The laser toner cartridge might be damaged.
- The internal part of the printer is damaged.

- Ensure to install the cartridge correctly.
- Please use the original laser toner cartridge.

Note: • The faults above can be mitigated by cleaning or replacing the cartridge. If the problem persists, please contact the customer service center. See the Three Guarantees certificate for contact details.

12 Product Specifications

Note: • Specification values are slightly different for different models of printers with different functions. These values are based on the initial data. For more information about the latest specification, please visit: www.pantum.com.

Overview of the Specifications

Product Size(W*D*H)	BM2300/BM2300W/BM2300NW /BM1800/BM1800W Series:396mm*297.5mm*249mm
	BM2300A/BM2300ANW Series: 415mm*327.5mm*293mm
Product Weight	BM2300/BM2300W/BM2300NW /BM1800/BM1800W Series: 7.5Kg(No wrappage, with random cartridges)
	BM2300A/BM2300ANW Series: 8.6Kg (No wrappage, with random cartridges)
Print Environment	Optimal Printing Temp Range:10-32°C
	Print humidity range: 20%RH~80%RH
Power Voltage	110V Model:AC100~127V ; 50Hz/60Hz; 6A
	220V Model:AC220~240V; 50Hz/60Hz; 3A
Noise (SPL)	Print: ≤52dB(A)
	Standby: ≤30dB
Power Consumption	Print: Average 370W
	Standby: ≤45W
	sleep: ≤2.5W
	Shutdown: ≤0.5W
	network standby: the model with wireless function: ≤3.00W the model without wireless function: ≤2.00W
Default automatic shutdown time (for EU only)	4 hours

	Microsoft Windows XP/ Windows 7/ Windows 8.1/ Windows 10/ Windows 11/ Windows Server 2012/2016/2019/2022 (32/64 Bit)
	macOS 10.10/10.11/10.12/10.13/10.14/10.15/11.0/11.1/11.2/11.3/11.4/11.5/11.6/12.0/12.1/12.2/12.3/12.4/12.5/12.6/13.0/13.1/13.2/13.3/13.4/13.5/13.6/14.0/14.1/14.2/14.3
Operating system	Linux Ubuntu 16.04(32/64 Bit)/ Ubuntu 18.04/Ubuntu 20.04/ Ubuntu 21.10/Ubuntu 22.04(64 Bit)
	iOS 11.0-15.0
	Android 6.0-12.0
	HarmonyOS 2.0-3.0
	Hi-speed USB 2.0
Communication interface	10/100Base-Tx Ethernet(Applicable for network model)
	Wi-Fi 802.11b/g/n (Applicable for Wi-Fi model only)
Processor	800MHz
Memory	128MB/256MB
	BLE: 2400MHz – 2483.5MHz
Frequency Band	Wi-Fi 2.4GHz : 2400MHz – 2483.5MHz
	Wi-Fi 5GHz(if applicable) : 5150MHz - 5350MHz;5470 MHz - 5725MHz
	Wi-Fi 5.8GHz(if applicable) : 5725MHz - 5850MHz
Note:The above frequency bands are common frequency bands, and different markets will restrict the use of certain frequency bands according to the country's regulatory requirements.	
	BLE: ≤10.00dBm EIRP
Maximum output power (Declaration for EU Compliance)	WLAN 2.4GHz : ≤20.00dBm EIRP
	WLAN 5GHz(if applicable) : ≤20.00dBm EIRP
	WLAN 5.8GHz(if applicable) : ≤14.00dBm EIRP

Print Specifications

Print Speed	BM2300/BM2300W/BM2300NW/BM2300A/BM2300AW Series: 22 ppm (A4)/23ppm (Letter)
	BM1800/BM1800W Series: 18 ppm (A4)/19ppm (Letter)
Print Time of First Page	<7.8 s
Print Language	GDI

Copy Specifications

Copy Speed	22cpm (A4)/23cpm (Letter)
FCOT	Flatbed <10 s ADF<12 s
Maximum number of continuous copies/pages	99 pages
Zoom ratio	20%~400%
Other Copy Functions	ID copy, Receipt copy, N-up copy, Clone copy, Poster copying, manual duplex copying, collate copying

Scan Specifications

Scan Type	Flatbed +ADF
Maximum Scan Size	Flatbed:216×297mm ADF:216 x 356 mm
Chromoscan	Yes
Scan Output Function	Scan to E-mail, PC, FTP and SMB

PANTUM